



**COMPAL** Server™

---

# SD221-8A

# User Manual

---

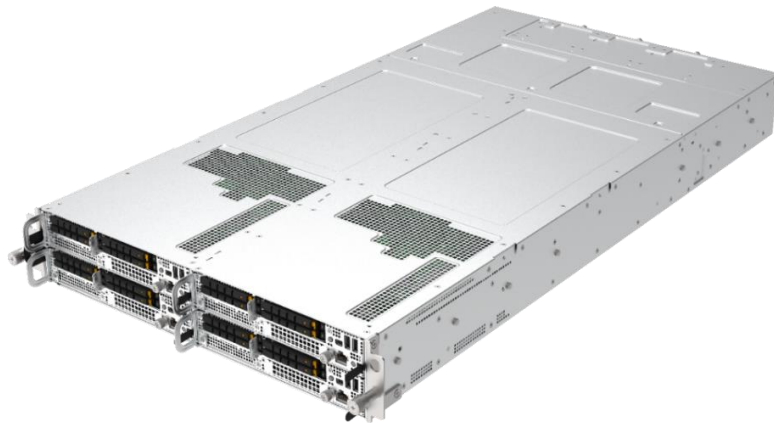

**COMPALSERVER™ User Manual V1.1**

**2024/04/29**

# Table of Contents

<b>Safety and Warnings</b> .....	<b>3</b>
<b>Chapter 1 Specification</b> .....	<b>37</b>
<b>Chapter 2 Server System Overview</b> .....	<b>38</b>
<b>2.1 Chassis Dimension</b> .....	<b>38</b>
<b>2.2 Front Side (In node)</b> .....	<b>38</b>
<b>2.3 System Rear View</b> .....	<b>39</b>
<b>2.4 Node Support Configuration</b> .....	<b>39</b>
4 SSD + 1 PCIe + OCP .....	39
2 SSD + 2 PCIe + OCP .....	40
<b>2.5 Power Supply (PSU) View</b> .....	<b>41</b>
<b>Chapter 3 LED Definition</b> .....	<b>42</b>
Hard Drive LEDs.....	42
Chassis CMC and Node BMC Management port LEDs.....	42
PSU LEDs The LED located on each PSU are bi-colored (Red & Green or Amber & Green depending on the brands of the PSU) and indicate the status of the power supply in the following mode. LED Definition: .....	43
<b>Chapter 4 Installation &amp; Removal</b> .....	<b>44</b>
<b>4.1 System Components</b> .....	<b>44</b>
PSU Removal .....	44
Fan Removal.....	44
<b>4.2 Node Components</b> .....	<b>45</b>
7mm SSD Removal .....	45
Air Duct Removal .....	46
M.2 Removal .....	47
Memory Removal.....	48
CPU & Heatsink .....	49
Riser Card Modules and PCIe Adapter .....	51
<b>4.3 Chassis Rail Kits</b> .....	<b>56</b>
<b>Chapter 5 Motherboard Overview</b> .....	<b>57</b>
<b>5.1 Connectors</b> .....	<b>57</b>
<b>5.2 CPU Sockets and DIMM Slots</b> .....	<b>58</b>
DIMM Population rule .....	58

<b>Chapter 6</b>	<b>System Management .....</b>	<b>59</b>
6.1	Management topology .....	59
6.2	Chaining Management.....	60
<b>Chapter 7</b>	<b>System Operation Mode .....</b>	<b>61</b>
7.1	Performance Mode settings.....	61

# Safety and Warnings



**CAUTION:**

Before installing and starting up a device, please observe the safety instructions listed in the following sections. This will help you to avoid making serious errors that could impair your health, damage the device and endanger the data base.



**CAUTION:**

To reduce the risk of electric shock, this equipment must be installed by trained service personnel in a restricted-access location.



**CAUTION:**

Use certified Optical Fiber Transceiver Class1(1) Laser Product.

Or

Laser Class 1 optical transceiver shall be used only.

When laser products (such as CD-ROMs, DVD drives, fiber optic devices, or transmitters) are installed, note the following:

- Do not remove the covers. Removing the covers of the laser product could result in exposure to hazardous laser radiation.
- There are no serviceable parts inside the device.
- Use of controls or adjustments or performance of procedures other than those specified herein might result in hazardous radiation exposure.



**CAUTION:**

Connect all power cords to a properly wired and grounded electrical outlet. The power control button on the device and the power switch on the power supply do not turn off the electrical current supplied to the device. The device also might have more than one power cord. To remove all electrical current from the device, ensure that all power cords are disconnected from the power source.

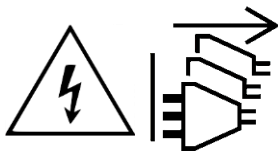

**CAUTION:**

- Replacement of a battery with an incorrect type that can defeat a safeguard.
- Disposal of a battery into fire or a hot oven, or mechanically crushing or cutting of a battery, that can result in an explosion.
- leaving a battery in an extremely high temperature surrounding environment that can result in an explosion or the leakage of flammable liquid or gas; and
- A battery subjected to extremely low air pressure that may result in an explosion or the leakage of flammable liquid or gas.



**CAUTION:**

The following label indicates a hot surface nearby.



**CAUTION:**

Hazardous energy is present when the server is connected to the power source. Always replace the blade cover before installing the server.



**CAUTION:**

Hazardous moving parts are nearby.



**CAUTION:**

Slide/rail mounted equipment is not to be used as a shelf or work space. Do not add weight to slide/rail mounted equipment.



## Installation Safety Information

### Preparing for startup

The devices comply with the relevant safety regulations for information technology equipment.

The requirements, which need to be fulfilled at the site of installation, are described in the user documentation for this device. Please contact the service center if there is any doubt as to the safety of installing the device at the intended site.

### Transporting, unpacking, installing

Condensation may form when the device is brought into the operations room from a colder environment. Wait until the device has warmed up to the room temperature and is totally dry before starting it. The acclimation time depends on the device and its design.

### Connecting data cables



**CAUTION:**

No data transmission lines may be connected or disconnected during a storm (danger of being struck by lightning).

When wiring the devices, the cables need to be connected or removed in the order described in the user document for the device. When connecting or disconnecting any of the leads, always hold them by the plug. Never pull on the cables themselves. Doing so could cause a cable to become detached from the plug.

#### Connecting the system to the power mains

Please check devices with adjustable rated voltage to determine whether the preset rated voltage of the device conforms to the local mains voltage. An incorrect setting leads to damage to or destruction of the device.

Before operating, check whether all the cables and wires are in perfect, undamaged condition. Ensure in particular that the cables have not been bent, have not been laid too tightly round corners, and that there are no objects located on top of them. Also make sure that all connectors have a tight fit. Defective screening or wiring may damage your health (electric shock) and can damage other devices.

Devices with power plugs are equipped with a safety-tested AC power line of the country of use and may only be connected to an approved shock-proof socket. This may otherwise result in an electric shock.

The product will be installed in ITE Room through skilled/service person and only applicable connect to 240 Vdc/ac outlet from certified Power distribution Unit (PDU)

Suitable for installation in Information Technology Rooms in accordance with Article 645 of the National Electrical Code and NFPA 75.

## Safety during operation

### Avoiding short circuits

Make sure that no objects (e.g. jewelry, paper clips, etc.) or liquids get inside the device. This can lead to electric shocks or short-circuits.

### Ventilation slots

Please make sure that the air vents are not blocked or collect dust as this may lead to the risk of overheating while the device is in operation. This could lead to operating faults.

## **Proper operation**

Proper operation and compliance with the EMC (electromagnetic compatibility) limit values is only guaranteed when the housing cover is mounted correctly and the doors are closed (cooling, fire protection, screening against electrical, magnetic, and electromagnetic fields).

### **Switch off in the event of malfunction and during servicing**

Devices are not disconnected from the mains by simply switching them off.

In the event of a malfunction or servicing, the devices need to be disconnected from the mains immediately.

Please proceed as follows:

- Switch off the devices,
- Pull out the mains plug (also refer to the device's user documentation),
- Inform Service.
- Devices that are connected to one or more uninterruptible power supplies (UPS's) will continue to operate even if the plug to the UPS ('s) is pulled. You therefore need to shut down the UPS ('s) in accordance with the accompanying user documentation.

## **Maintenance Safety**

### **Expanding, repairing**

When expanding the device, use only parts that have been approved for the device. Failure to observe this rule can lead to violation of the electromagnetic compatibility (EMC) or safety standards and cause device malfunctions.

The device only be repaired by authorized, qualified personnel. Improper repairs may expose the user to considerable danger (electric shock, fire).

Unauthorized opening of the device or individual parts of the device can also expose the user to considerable danger. Unauthorized opening of the devices or parts thereof results in voiding of the warranty and exclusion of liability.

### **Handling batteries**

The life of the batteries/accumulators in the devices is approx. three to five years. In order to ensure the functional reliability, they must be exchanged at the end of this time. The batteries may only be changed by authorized personnel. The local regulations for disposal of special waste must be observed when disposing of the batteries.

Batteries can cause danger, e.g. fire, if handled incorrectly. Therefore avoid opening, puncturing or pressing together batteries. Never throw batteries on a fire.

### **Special safety note for rack cabinets**

Do not use device units mounted on pull-out rails as a surface on which to put things or as a work surface, and strictly avoid leaning on or against them.

### **Setting up a rack**

At least two people must always be used to set up a rack because of its weight and their size.

This is the only way to avoid accidents and damage to the equipment.

To install the server in the rack cabinet, please observe the instructions in the relevant system installation manual.

### **Overload protection**

Make sure if connecting a number of devices to the same circuit that you do not overload the current distribution. Please observe the nominal values indicated on the product ident plates.

### **Stabilizing the racks**

Even when the rack has been secured against tipping over, only one slide-in module may be removed on its rails at any one time. There is no guarantee that the rack will remain stable if several modules are pulled out simultaneously.

### **Second person for work on racks**

Two or more people are required to insert or remove rack trays as these are large and heavy.

This is particularly true regarding servers, peripheral devices and UPS's. This information can be found in the device's user documentation.

## Regional EMC Compliance Information

### FCC Statement (USA only)

This device complies with Part 15 of the FCC Rules. Operation is subject to the following two conditions:

- (1) this device may not cause harmful interference, and
- (2) this device must accept any interference received, including interference that may cause undesired operation.

### Class A



This equipment has been tested and found to comply with the limits for a Class A digital device pursuant to Part 15 of the FCC Rules. These limits are designed to provide reasonable protection against harmful interference when the equipment is operated in a commercial environment.

This equipment generates, uses, and can radiate radio frequency energy and, if not installed and used in accordance with the manufacturer's instruction manual, may cause harmful interference with radio communications. Operation of this equipment in a residential area is likely to cause harmful interference, in which case you will be required to correct the interference at your own expense.

### INDUSTRY CANADA (Canada only)

#### CAN ICES-003(A) / NMB-003(A)

This Class B (or Class A, if so indicated on the registration label) digital apparatus meets the requirements of the Canadian Interference-Causing Equipment Regulations.

Cet appareil numérique de la Classe B (ou Classe A, si ainsi indiqué sur l'étiquette d'enregistrement) respecte toutes les exigences du Règlement sur le Matériel Brouilleur du Canada.

## CE Declaration of Conformity (EUROPE only)



This product has been tested in accordance to, and complies with the European Low Voltage Directive (2014/35/EU), European EMC Directive (2014/30/EU), Restriction of the Use of certain Hazardous Substances in Electrical and Electronic Equipment (RoHS) Directive 2011/65/EU and Ecodesign requirements for energy-related products (ErP) Directive 2009/125/EC.

The product has been marked with the CE Mark to illustrate its compliance.

### Warning

This equipment is compliant with Class A of CISPR 32. In a residential environment this equipment may cause radio interference.

## UKCA Declaration of Conformity (England, Wales and Scotland only)



This equipment is confirmed to comply with the requirements set out in the UK Conformity, assessed on the Approximation of the Laws of the Member States relating to Low-voltage Directive (Safety) Regulations 2016, Electromagnetic Compatibility Regulations 2016, The Restriction of the Use of Certain Hazardous Substances in Electrical and Electronic Equipment Regulations 2012 and The Ecodesign for Energy-Related Products and Energy Information (Amendment) (EU Exit) Regulations 2019.

## CCC (China only)



The following CCC EMC Warning is marked on the product: EMC Warning is required for Class A products.

# Environmental compliance

## Restricted Material Compliance

### EU RoHS

The devices are designed to comply with the applicable restricted substance requirements of the European Union's Restriction of the use of certain Hazardous Substances in Electrical and Electronic Equipment (RoHS) Directive (2011/65/EC) as amended, including Directive (2015/863/EU) which added four phthalates to the RoHS Directive's Annex II substance restriction list. The RoHS Directive requires self-declaration to RoHS restrictions through the **Declaration of Conformity (DoC)** process and CE marking.

### EU REACH compliance

The European Union's Regulation on the Registration, Evaluation, Authorization and Restriction of Chemicals (REACH) (2006/1907/EC) entered into force on June 1, 2007. Pursuant to Article 33, COMPAL communicates information regarding Substances of Very High Concern (SVHC) that are contained in articles in a concentration above 0.1% by weight to its customers and to consumers, upon request. To meet these compliance obligations, COMPAL actively monitors the European Chemical Agency's (ECHA) SVHC candidate list and adds SVHCs that have been added to the ECHA authorization list.

### EU Batteries Directive - Restricted Substances

The devices are designed to comply with the applicable restricted substance requirements of the European Union's Batteries Directive (2006/66/EC) as amended, including Directive (2013/56/EU). All batteries or accumulators shall not contain more than 0.0005% (5 ppm) of mercury by weight and portable batteries or accumulators, including those incorporated into appliances, shall not contain more than 0.002% of cadmium by weight.

### Packaging - Restricted Substances

No CFCs (chlorofluorocarbons), HCFCs (hydrofluorocarbons) or other ozone depleting substances are used in the packaging material. Chromium, lead, mercury, cadmium are not intentionally added to packaging materials and are not present in a cumulative concentration greater than 100 ppm. No halogenated plastics or polymers are used for packaging material. Printed user documentation is bleached in a chlorine-free process.

## California Proposition 65 (US CA only)

California's Proposition 65, the Safe Drinking Water and Toxic Enforcement Act of 1986, was enacted as a ballot initiative in November 1986. The Proposition was intended by its authors to protect California citizens and the State's drinking water sources from chemicals known to cause cancer, birth defects or other reproductive harm, and to inform citizens about exposures to such chemicals. The device has warning label on exterior packaging

## EU WEEE

The device may not be disposed of with household rubbish. This appliance is labelled in accordance with European Directive 2012/19/EU concerning used electrical and electronic appliances (waste electrical and electronic equipment – WEEE).

The guideline determines the frame-work for the return and recycling of used appliances as applicable throughout the EU. To return your used device, please use the return and collection systems available to you.



## China RoHS (China only)

The device shipping directly into China which are manufactured on or after March 1st, 2007, are China RoHS compliant.

China RoHS Declaration Table

部件名称	有害物质					
	铅(Pb)	汞(Hg)	镉(Cd)	六价铬 (Cr(VI))	多溴联苯 (PBB)	多溴二苯醚 (PBDE)
PCB 板	×	○	○	○	○	○
结构件	×	○	○	○	○	○
芯片及 其他主动零件	×	○	○	○	○	○
连接器	×	○	○	○	○	○
风扇、散热件	×	○	○	○	○	○
硬盘	×	○	○	○	○	○
助焊剂, 散热膏, 标签及 其他耗材	×	○	○	○	○	○

本表格依据 SJ/T 11364 的规定编制。

○：表示该有害物质在该部件所有均质材料中的含量均在 GB/T 26572 规定的限量要求以下。

×：表示该有害物质至少在该部件的某一均质材料中的含量超出 GB/T 26572 规定的限量要求。

注：表中标记“×”的部件，皆因全球技术发展水平限制而无法实现有害物质的替代。

## Energy saving compliance

### ErP Lot9 Information Sheet

#### - Servers & Storage Products -

The EU Commission Regulation (EU) 2019/424 of 15 March 2019 laying down ecodesign requirements for servers and data storage products pursuant to Directive 2009/125/EC of the European Parliament and of the Council and amending Commission Regulation (EU) No 617/2013. (ErP Lot9)

Information to be provided by manufacture (EU) 2019/424 – Annex II section 3.1 and 3.3

Annex II section 3.1 Requirement		Information
(a)	product type	Server
(b)	manufacturer's name, registered trade name and registered trade address at which they can be contacted	Compal Electronics Inc. No. 581 & 581-1, Ruiguang Rd., Neihu District Taipei City 11492, Taiwan (R.O.C.)
(c)	product model name, model number and serial number	SD221-8A
(d)	year of manufacture	2024
(e)	PSU efficiency at 10 % (if applicable), 20 %, 50 % and 100 % of rated output power	reference PSU efficiency and power factor table
(f)	power factor at 50 % of the rated load level	reference PSU efficiency and power factor table
(g)	PSU rated power output (Watts)	reference PSU efficiency and power factor table
(h)	idle state power (Watts)	<u>High-end</u> 2P : 207.2 Watts <u>Low-end</u> 2P : 167.0 Watts
(i)	list of all components for additional idle power allowances, if any (additional PSU, HDDs or SSDs, additional memory, additional buffered DDR channels, additional I/O devices)	<u>High-end</u> 2P : 1 additional PSU, 2.5" SSD x2, additional 1532GB memory, additional 1G Port x3, 10G Port x2 <u>Low-end</u> 2P : 1 additional PSU, 2.5" SSDx2, additional 380GB memory, additional 1G Port x3
(j)	maximum power (Watts)	<u>High-end</u> 2P : 1212.2 Watts <u>Low-end</u> 2P : 463.95 Watts
(k)	declared operating condition class	ASHRAE A2
(l)	idle state power (Watts) at the higher boundary temperature of the declared operating condition class	<u>High-end</u> 2P : 417.7 Watts <u>Low-end</u> 2P : 337.0 Watts
(m)	the active state efficiency and the performance in active state of the server	<u>High-end</u> 2P : Efficiency= 102.1, Performance= 74.9 <u>Low-end</u> 2P : Efficiency= 65.0, Performance= 22.0

Annex II section 3.1 Requirement		Information
(n)	information on the secure data deletion functionality	Compal offer two ways to accomplish secure data deletion 1. Use Linux dd command to do the secure data deletion, please follow the steps below: Step 1: Plug in the drive (e.g. USB, other storage) to an available port. Step 2: Boot into Linux OS from the plug in device. Step 3: Run the following command as sudo in your Terminal application in order to check the available storage devices on your system and the file system they are using. Step 4: input test using “dd if=/dev/zero of=/dev/<destination partition> bs=xxxx”. Step 5: Reboot the OS. 2. Erase Utilities provided by third-party vendors. Please contact the manufacturer of your storage device to obtain the deletion utility matching that device.
(o)	list recommended combinations with compatible chassis (for blade servers)	None
(p)	if a product model is part of a server product family, a list of all model configurations that are represented by the model shall be supplied	reference PRD
Annex II section 3.3 Requirement		Information
(a)	indicative weight range of the following critical raw materials: (a) Cobalt in the batteries; (b) Neodymium in the HDDs	(a) less than 5 g (b) above 25 g (Need PM provide information. If we don't survey, we may declare “above 25 g”)
(b)	instructions on the disassembly operations	reference Chapter4 Installation / Removal

PSU efficiency and power factor

Power Supply Model Number	Rating (Watt)	80 Plus Rating	Minimum PSU efficiency				Minimum power factor
			10%	20%	50%	100%	
R1CA2162B	1600	Platinum	NA	90.00%	94.00%	91.00%	0.98
R1CA2162D	1600	Titanium	91.60%	94.17%	96.23%	95.41%	0.99
FSP1600-20FM	1600	Platinum	85.19%	94.48%	94.99%	92.54%	0.99
FSP1600-20HM	1600	Titanium	93.62%	95.15%	96.01%	93.53%	0.99

Note: From 2024/1/1, only Titanium PSU can be shipped into EU and UK region.

BSMI (台灣)

警告使用者：為避免電磁干擾，本產品不應安裝或使用於住宅環境。

## 安全和警告



警告：

在安裝和啟動設備前，請遵守以下章節列出的安全須知。這將幫助您避免可能損害您的健康，損壞設備並危及資料庫的嚴重錯誤。



警告：

為減少觸電風險，必須由專業人員進入受限訪問位置安裝本設備。



警告：

安裝鐳射產品（如 CD-ROM、DVD 驅動器、光纖設備或發送設備）時，請注意以下事項：

- 不要拆除產品的外殼。拆除產品外殼可能導致遭受激光輻射的危害。
- 本設備內部沒有可維修的部件。
- 未按照本冊中指定的步驟進行控制、調整或操作時，可能會導致危險的輻射暴露。



警告：

請將設備電源線插入妥善接地的電源插座。如果必須使用延長線，請使用帶有正確接地插頭的 3 芯纜線。設備上的電源控制按鈕和電源上的電源開關，並不能完全切斷提

供給設備的電流。本設備還可能有多根電源線。要使設備徹底斷電，請確保斷開所有電源線與電源的連接。

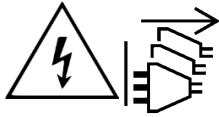

警告：

- 置換可能影響安全防護的錯誤型式的電池;
- 電池丟入火焰或烤箱中,或將電池作可能導致爆炸的機械擠壓或切割;
- 電池置於可能導致爆炸或可燃性液體或氣體洩漏的高溫環境中;且
- 電池承受可能導致爆炸或可燃性液體或氣體洩漏的極度低氣壓。



警告：

下方標籤表示附近有熱表面。



警告：

伺服器連接到電源時存在危險能量, 請勿在蓋板卸下的狀態下操作您的設備

警告：

附近存在危險的移動部件。





**警告：**

裝有滑軌的設備不能用作架子或工作空間。

不要增加裝有滑軌的設備的重量。



## 安裝的安全注意事項

### 準備啟動

這些設備符合資訊技術設備的相關安全規定。

在本設備的使用者文檔中描述了現場安裝需要滿足的要求。如有任何疑問，請與服務中心聯繫，以確保在指定地點安裝設備的安全性。

### 運輸、開箱、安裝

當設備從較冷的環境進入操作室時，可能會形成凝結。等到設備溫度上升到室溫，且完全乾燥後再啟動。適應時間取決於設備及其設計。

### 連接資料電纜



**警告：**

請勿在雷暴天氣期間連接或斷開任何資料電纜的連接（被雷擊的危險）。

當連接設備時，需要按照使用者文檔中描述的順序連接或拆除電纜。當連接或切斷任何導線時，每次都要用插頭把它們連接起來。不要把電纜拉到電纜上面。這樣做可能會導致電纜脫離插頭。

### 連接系統與電源

請檢查具有可調額定電壓的設備，以確定該設備的預置額定電壓是否符合當地的電源電壓要求。錯誤的設置會導致設備的損壞或破壞。

在操作前，檢查所有的電纜和電線是否完好無損。特別要確保電纜沒有彎曲，沒有過緊的彎角，以及沒有物體放置在它們上面。還要確保所有的連接器都是緊配合。有缺陷的篩檢或佈線可能會損傷您的健康（觸電），並可能損壞其他設備。

帶有電源插頭的設備配備了國家安全測試的交流電源線路，可能只連接到一個經認可的防震插座。否則這可能會導致觸電。

## 操作安全

### 避免短路

確保沒有物品（如珠寶、紙夾等）或液體進入設備內。這可能會導致電擊或短路。

### 通風槽

請確保空氣通風孔沒有被堵塞或集塵，因為這可能會導致設備在運行時出現過熱的危險，產生運行故障。

## 正確操作

只有正確安裝殼蓋和關閉所有的門（冷卻、防火，遮罩電、磁和電磁場），才能保證正確的操作和符合 EMC（電磁相容性）限值。

### 發生故障或維修時切斷電源

僅僅通過關閉設備不能斷開設備與電源的連接。

發生故障或維修時，需立即斷開設備與電源的連接。

請進行如下操作：

- 關閉設備，
- 拔掉電源插頭（也參考設備的使用者文檔），
- 報修。
- 即使插入 UPS（系統）的插頭被拔掉，連接到一個或多個不斷電供應系統（UPS 系統）的設備也會繼續運行。因此，您需要按照隨附的使用者文檔關閉 UPS（系統）。

## 維護安全

### 擴展、修復

在擴展設備時，只能使用經過批准的部件。如果不遵守此規則，可能會違反電磁相容性（EMC）或安全標準，並導致設備故障。

本設備只能由經過授權的、有資格的人員進行維修。不適當的修理可能導致用戶面臨極大的危險（觸電、火災）。

未經授權打開設備或設備的各個部件，也會導致用戶面臨極大的危險。未經授權打開設備或其各個部件，會造成擔保免責條款無效。

### 處理電池

設備中的電池/蓄電池的使用壽命大約為 3 到 5 年。為了保證功能可靠性，必須在其壽命結束時進行更換。電池只能由授權人員進行更換。處理電池時必須遵守關於特殊廢物處理的地方性法規。

電池會造成危險，例如處理不當會引起火災。因此，避免打開、刺穿或擠壓電池。不要把電池扔在火上。

### 機架櫃安全特別提示

不要把安裝在伸縮滑軌上的設備作為放置東西的表面或工作表面，並且要嚴格避免倚靠或背靠它們。

### 搭建機架

根據它的重量和尺寸，必須至少有兩個人來搭建機架。

這是避免事故和設備損壞的唯一方法。

要在機架櫃中安裝伺服器，請參照相關系統安裝手冊中的使用說明。

### 超載保護

確保將一些設備連接到相同的電路中，這樣不至使當前的分佈超載。請參照在產品凹版上所注明的標值。

### 穩定機架

即使當機架已被固定，但在任何時候，只有一個滑塊模組可以在它的滑軌上被移除。如果多個模組同時被抽出，則不能保證機架保持穩定。

### 第二個人在機架上工作

需要兩個或更多的人來插入或拆卸機架託盤，因為這些託盤又大又重。

這對於伺服器、週邊設備和 UPS 來說尤其如此。這些資訊可以在設備的使用者文檔中獲取。

# 區域 EMC 合規信息

## FCC 認證注意事項（僅適用於 USA）

本設備符合 FCC 的第 15 條規定。操作遵循以下兩個條件：

- (1) 本設備可能不會造成有害的干擾，與
- (2) 本設備必須能承受接收到的任何干擾，包括可能引起非預期作業的干擾。

## A 類



經測試，本設備符合 FCC 規則第 15 條對 A 類數位設備的限制規定。這些限制旨在提供合理的保護，防止設備在商業環境中運行時產生有害干擾。

本設備可以產生、利用和發射無線射頻能量。如果不按照製造商的說明手冊中的要求安裝和使用本設備，有可能會產生有害的射頻干擾。在居民區運行此設備可能會造成有害干擾，在這種情況下，使用者需要自費消除干擾。

## 加拿大工業標準（僅適用於加拿大）

### CAN ICES-003(A) / NMB-003(A)

B 類（或 A 類，如果註冊標籤上有注明）數位設備符合加拿大引起干擾設備規定的所有要求。

Cet appareil numérique de la Classe B (ou Classe A, si ainsi indiqué sur l'étiquette d'enregistrement) respecte toutes les exigences du Règlement sur le Matériel Brouilleur du Canada.（譯文同上段）

## CE 符合性聲明（僅適用於歐洲）



本產品已根據歐洲低電壓指令(2014/35/EU)和歐洲電磁相容指令(2014/30/EU)、歐盟電子電機產品危害物質限用指令(2011/65/EU)和歐盟能源相關產品生態化設計指令(2009/125/EC)進行測試。

本產品已被標記為 CE 標誌，以說明其遵從性。

### 警告

本產品符合 CISPR 32 的 A 類標準。在居住環境中，本產品可能會造成射頻干擾。

## 英國產品符合性聲明（僅適用於英格蘭、威爾士及蘇格蘭）



本產品已確認符合英國符合性評估中規定的要求，根據低電壓指令（安全）法規(2016)、電磁兼容性法規(2016)、英國電子電機產品危害物質限用指令(2012)和英國能源相關產品生態化設計指令(2019)進行測試。

## CCC (僅適用於中國)



在產品上有標記以下的 CCC EMC 警告：A 類產品需要 EMC 警告。

# 產品環境法規符合性

## 限制物質法規符合性

### 歐盟危害物質限用指令

本產品已根據歐盟危害物質限用指令(2011/65/EC) 限制物質要求，包括指令 (2015/863/歐盟) 將四種鄰苯二甲酸酯添加到 RoHS 指令的附件 II 物質限制清單中。RoHS 指令要求通過符合性聲明(DoC) 流程和 CE 標誌對 RoHS 限制進行自我聲明。

### 歐盟 REACH 法規

歐盟關於化學品註冊、評估、授權和限制的法規 (REACH) (2006/1907/EC) 於 2007 年 6 月 1 日生效。根據第 33 條，仁寶應要求向其客戶和消費者傳達有關產品中所含濃度超過 0.1% 重量的高度關注物質 (SVHC) 的資訊。為履行這些法規義務，仁寶積極監控歐洲化學品管理局 (ECHA) 的 SVHC 候選清單及 ECHA 授權清單。

### 歐盟電池指令-限制物質

本產品設計符合經修訂的歐盟電池指令 (2006/66/EC) 的適用限制物質要求，包括指令 (2013/56/EU)。所有電池或蓄電池的汞含量按重量計不得超過 0.0005% (5 ppm)，可攜式電池或蓄電池，包括安裝在產品中的電池，鎘的重量不得超過 0.002%。

### 歐盟包材指令-限制物質

包裝材料中不使用 CFC (氯氟烴)、HCFC (氫氟烴) 或其他消耗臭氧層物質。鉻、鉛、汞、鎘並非有意添加到包裝材料中，並且累積濃度不超過 100 ppm。包裝材料不使用鹵化塑膠或聚合物。印刷手冊不得使用含氯漂白的紙。

### 加州 65 號提案 (僅適用於美國加州)

加利福尼亞州的第 65 號提案，即 1986 年的《安全飲用水和有毒物質執法法案》，於 1986 年 11 月作為一項投票倡議頒佈。該提案的主旨在保護加州公民和該州的飲用水源免受已知會導致癌症、出生缺陷或其他生殖危害的化學物質的侵害，並告知公民接觸此類化學物質的情況。本產品設計外包裝上有相關的警告標籤。

## 歐盟廢電子電機設備指令

本產品不得與家庭垃圾一起處理。關於已使用的電子和電器設備（電子廢棄物-WEEE），本設備按歐洲指令 2012/19/EU 指令已作標記。

該指南確定了適用於整個歐盟的舊電器的回收和回收框架。要退回您使用過的設備，請使用您可用的退回和收集系統。



## 台灣 RoHS(僅適用於台灣地區)

設備名稱： 伺服器 Equipment name		型號（型式）：SD221-8A Type designation (Type)				
單元 Unit	限用物質及其化學符號 Restricted substances and its chemical symbols					
	鉛 Lead (Pb)	汞 Mercury (Hg)	鎘 Cadmium (Cd)	六價鉻 Hexavalent chromium (Cr <sup>+6</sup> )	多溴聯苯 Polybrominated biphenyls (PBB)	多溴二苯醚 Polybrominated diphenyl ethers (PBDE)
外殼	—	○	○	○	○	○
機械部件	—	○	○	○	○	○
電路板組件	—	○	○	○	○	○
電線/連接器	—	○	○	○	○	○
電源設備	—	○	○	○	○	○
儲存裝置	—	○	○	○	○	○

備考 1. “○” 係指該項限用物質之百分比含量未超出百分比含量基準值。  
 Note 1 : “○” indicates that the percentage content of the restricted substance does not exceed the percentage of reference value of presence.

備考 2. “—” 係指該項限用物質為排除項目。  
 Note 2 : The “—” indicates that the restricted substance corresponds to the exemption.

# 安全和警告



**警告：**

在安装和启动设备前，请遵守以下章节列出的安全须知。这将帮助您避免可能损害您的健康，损坏设备并危及数据库的严重错误。



**警告：**

为减少触电风险，必须由专业人员进入受限访问位置安装本设备。



**警告：**

安装激光产品（如 CD-ROM、DVD 驱动器、光纤设备或发送设备）时，请注意以下事项：

- 不要拆除产品的外壳。拆除产品外壳可能导致遭受激光辐射的危害。
- 本设备内部没有可维修的部件。
- 未按照本册中指定的步骤进行控制、调整或操作时，可能会导致危险的辐射暴露。



**警告：**

将设备电源线缆连接到正确的接地电源插座中。如果必须使用延长线缆，请使用具有正确接地插头的三线线缆。设备上的电源控制按钮和电源上的电源开关，并不能完全切断提供给设备的电流。本设备还可能有多根电源线。要使设备彻底断电，请确保断开所有电源线与电源的连接。



警告：

- 置换可能影响安全防护的错误型式的电池;
- 电池丢入火焰或烤箱中,或将电池作可能导致爆炸的机械挤压或切割;
- 电池置于可能导致爆炸或可燃性液体或气体泄漏的高温环境中;且
- 电池承受可能导致爆炸或可燃性液体或气体泄漏的极度低气压。



警告：

下方标签表示附近有热表面。



警告：

当服务器与电源连接时，潜在危险能量. 请勿在任何盖板被卸下的情况下操作设备。

警告：

附近存在危险的移动部件。



警告：

装有滑轨的设备不能用作架子或工作空间。

不要增加装有滑轨的设备的重量。



## 安装的安全注意事项

### 准备启动

这些设备符合信息技术设备的相关安全规定。

在本设备的用户文档中描述了现场安装需要满足的要求。如有任何疑问，请与服务中心联系，以确保在指定地点安装设备的安全性。

### 运输、开箱、安装

当设备从较冷的环境进入操作室时，可能会形成凝结。等到设备温度上升到室温，且完全干燥后再启动。适应时间取决于设备及其设计。

### 连接数据电缆



**警告：**

请勿在雷暴天气期间连接或断开任何数据电缆的连接（被雷击的危险）。

当连接设备时，需要按照用户文档中描述的顺序连接或拆除电缆。当连接或切断任何导线时，每次都要用插头把它们连接起来。不要把电缆拉到电缆上面。这样做可能会导致电缆脱离插头。

### 连接系统与电源

请检查具有可调额定电压的设备，以确定该设备的预置额定电压是否符合当地的电源电压要求。错误的设置会导致设备的损坏或破坏。

在操作前，检查所有的电缆和电线是否完好无损。特别要确保电缆没有弯曲，没有过紧的弯角，以及没有物体放置在它们上面。还要确保所有的连接器都是紧配合。有缺陷的筛检或布线可能会损伤您的健康（触电），并可能损坏其他设备。

带有电源插头的设备配备了国家安全测试的交流电源线路，可能只连接到一个经认可的防震插座。否则这可能会导致触电。

## 操作安全

### 避免短路

确保没有物品（如珠宝、纸夹等）或液体进入设备内。这可能会导致电击或短路。

### 通风槽

请确保空气通风孔没有被堵塞或集尘，因为这可能会导致设备在运行时出现过热的危险，产生运行故障。

## 正确操作

只有正确安装壳盖和关闭所有的门（冷却、防火，屏蔽电、磁和电磁场），才能保证正确的操作和符合 EMC（电磁兼容性）限值。

### 发生故障或维修时切断电源

仅仅通过关闭设备不能断开设备与电源的连接。

发生故障或维修时，需立即断开设备与电源的连接。

请进行如下操作：

- 关闭设备，
- 拔掉电源插头（也参考设备的用户文档），
- 报修。
- 即使插入 UPS（系统）的插头被拔掉，连接到一个或多个不间断电源（UPS 系统）的设备也会继续运行。因此，您需要按照随附的用户文档关闭 UPS（系统）。

## 维护安全

### 扩展、修复

在扩展设备时，只能使用经过批准的部件。如果不遵守此规则，可能会违反电磁兼容性（EMC）或安全标准，并导致设备故障。

本设备只能由经过授权的、有资格的人员进行维修。不适当的修理可能导致用户面临极大的危险（触电、火灾）。

未经授权打开设备或设备的各个部件，也会导致用户面临极大的危险。未经授权打开设备或其各个部件，会造成担保免责条款无效。

### 处理电池

设备中的电池/蓄电池的使用寿命大约为 3 到 5 年。为了保证功能可靠性，必须在其寿命结束时进行更换。电池只能由授权人员进行更换。处理电池时必须遵守关于特殊废物处理的地方性法规。

电池会造成危险，例如处理不当会引起火灾。因此，避免打开、刺穿或挤压电池。不要把电池扔在火上。

### 机架柜安全特别提示

不要把安装在伸缩滑轨上的设备作为放置东西的表面或工作表面，并且要严格避免倚靠或背靠它们。

### 搭建机架

根据它的重量和尺寸，必须至少有两个人来搭建机架。

这是避免事故和设备损坏的唯一方法。

要在机架柜中安装服务器，请参照相关系统安装手册中的使用说明。

### 过载保护

确保将一些设备连接到相同的电路中，这样不至使当前的分布过载。请参照在产品凹版上所注明的标值。

### 稳定机架

即使当机架已被固定，但在任何时候，只有一个滑块模块可以在它的滑轨上被移除。如果多个模块同时被抽出，则不能保证机架保持稳定。

### 第二个人在机架上工作

需要两个或更多的人来插入或拆卸机架托盘，因为这些托盘又大又重。

这对于服务器、外围设备和 UPS 来说尤其如此。这些信息可以在设备的用户文档中获取。



# 区域 EMC 合规信息

## FCC 认证注意事项 (仅适用于 USA)

本设备符合 FCC 的第 15 条规定。操作遵循以下两个条件：

- (1) 本设备可能不会造成有害的干扰，与
- (2) 本设备必须能承受接收到的任何干扰，包括可能引起非预期作业的干扰。

## A 类



经测试，本设备符合 FCC 规则第 15 条对 A 类数字设备的限制规定。这些限制旨在提供合理的保护，防止设备在商业环境中运行时产生有害干扰。

本设备可以产生、利用和发射无线射频能量。如果不按照制造商的说明手册中的要求安装和使用本设备，有可能会产生有害的射频干扰。在居民区运行此设备可能会造成有害干扰，在这种情况下，使用者需要自费消除干扰。

## 加拿大工业标准 (仅适用于加拿大)

### CAN ICES-003(A) / NMB-003(A)

B 类（或 A 类，如果注册标签上有注明）数字设备符合加拿大引起干扰设备规定的所有要求。

Cet appareil numérique de la Classe B (ou Classe A, si ainsi indiqué sur l'étiquette d'enregistrement) respecte toutes les exigences du Règlement sur le Matériel Brouilleur du Canada. (译文同上段)

## CE 符合性声明 (仅适用于欧洲)



本产品已根据欧洲低电压指令(2014/35/EU)和欧洲电磁相容指令(2014/30/EU)、欧盟电子电机产品有害物质限用指令(2011/65/EU)和欧盟能源相关产品生态化设计指令(2009/125/EC)进行测试。

本产品已被标记为 CE 标志，以说明其遵从性。

### 警告

本产品符合 CISPR 32 的 A 类标准。在居住环境中，本产品可能会造成射频干扰。

## 英国产品符合性声明 (仅适用于英格兰、威尔士及苏格兰)



本产品已确认符合英国符合性评估中规定的要求，根据低电压指令（安全）法规(2016)、电磁兼容性法规(2016)、英国电子电机产品有害物质限用指令(2012)和英国能源相关产品生态化设计指令(2019)进行测试。

## 中国 CCC (China only)



在产品上有标记以下的 CCC EMC 警告：A 类产品需要 EMC 警告。

# 产品环境合规性

## 限制物质合规性

### 欧盟危害物质限用指令

本产品已根据欧盟危害物质限用指令(2011/65/EC) 限制物质要求，包括指令(2015/863/ 欧盟) 将四种邻苯二甲酸酯添加到 RoHS 指令的附件 II 物质限制清单中。RoHS 指令要求通过符合性声明 (DoC) 流程和 CE 标志对 RoHS 限制进行自我声明。

### 欧盟 REACH 法规

欧盟关于化学品注册、评估、授权和限制的法规 (REACH) (2006/1907/EC) 于 2007 年 6 月 1 日生效。根据第 33 条，仁寶应要求向其客户和消费者传达有关产品中所含浓度超过 0.1% 重量的高度关注物质 (SVHC) 的信息。为履行这些合规义务，仁寶积极监控欧洲化学品管理局 (ECHA) 的 SVHC 候选清单及 ECHA 授权清单。

### 欧盟電池指令-限制物质

本产品设计符合经修订的欧盟电池指令 (2006/66/EC) 的适用限制物质要求，包括指令 (2013/56/EU)。所有电池或蓄电池的汞含量按重量计不得超过 0.0005% (5 ppm)，便携式电池或蓄电池，包括安装在产品中的电池，镉的重量不得超过 0.002%。

### 欧盟包材指令-限制物质

包装材料中不使用 CFC (氯氟烃)、HCFC (氢氟烃) 或其他消耗臭氧层物质。铬、铅、汞、镉并非有意添加到包装材料中，并且累积浓度不超过 100 ppm。包装材料不使用卤化塑料或聚合物。印刷手册不得使用含氯漂白的纸。

### 加州 65 号提案 (仅限美国加州)

加利福尼亚州的第 65 号提案，即 1986 年的《安全饮用水和有毒物质执法法案》，於 1986 年 11 月作为一项投票倡议颁布。该提案的主旨在保护加州公民和该州的饮用水源免受已知会导致癌症、出生缺陷或其他生殖危害的化学物质的侵害，并告知公民接触此类化学物质的情况。本产品设计外包装上有相关的警告标签。

## 欧盟废电子电机设备指令

本产品不得与家庭垃圾一起处理。关于已使用的电子和电器设备（电子废弃物-WEEE），本设备按欧洲指令 2012/19/EU 指令已作标记。

该指南确定了适用于整个欧盟的旧电器的回收和回收框架。要退回您使用过的设备，请使用您可用的退回和收集系统。



## 中国 RoHS

在 2007 年 3 月 1 日或之后制造的直接运往中国的设备应符合中国 RoHS 标准。

中国 RoHS 表格

部件名称	有害物质					
	铅(Pb)	汞(Hg)	镉(Cd)	六价铬 (Cr(VI))	多溴联苯 (PBB)	多溴二苯醚 (PBDE)
PCB 板	×	○	○	○	○	○
结构件	×	○	○	○	○	○
芯片及 其他主动零件	×	○	○	○	○	○
连接器	×	○	○	○	○	○
风扇、散热件	×	○	○	○	○	○
硬盘	×	○	○	○	○	○
助焊剂，散热膏，标签及 其他耗材	×	○	○	○	○	○

本表格依据 SJ/T 11364 的规定编制。

○：表示该有害物质在该部件所有均质材料中的含量均在 GB/T 26572 规定的限量要求以下。

×：表示该有害物质至少在该部件的某一均质材料中的含量超出 GB/T 26572 规定的限量要求。

注：表中标记“×”的部件，皆因全球技术发展水平限制而无法实现有害物质的替代。

## **Copyright**

This publication, including all photographs, illustrations and software, is protected under international copyright laws, with all rights reserved. Reproduction of this manual, or the material contained herein, in any manner whatsoever without the written permission of COMPAL Electronics, Inc. is strictly forbidden.

Version 1.0 © COMPAL Electronics, Inc. All rights reserved.

# Chapter 1 Specification

<b>Form Factor</b>	2U 19" Rack-mount Chassis dimension: 850mm (D) x 442mm (W) x 87.3mm (H)
<b>CPU</b>	Dual AMD EPYC™ Genoa 9004 series processor family, up to <b>360W</b>
<b>xGMI</b>	Two CPU sockets on board, 4 xGMI links
<b>Memory</b>	<ul style="list-style-type: none"> <li>- 12 Channel support</li> <li>- 24 DDR5 DIMM slots</li> <li>- 12 DIMMs per CPU</li> <li>- Support RDIMM (3DS)</li> <li>- Speed up to DDR5-4800 (follow AMD POR)</li> </ul>
<b>Front I/O and LED</b>	<ul style="list-style-type: none"> <li>- Support 2 x USB 3.2 Gen1</li> <li>- Support 1 x mini DP Port</li> <li>- Support 1 x UID LED Button (integrate BMC Reset button)</li> <li>- Support 1 x Power LED Button</li> </ul>
<b>Internal I/O</b>	<ul style="list-style-type: none"> <li>- Support 1 x On Board TPM</li> <li>- Support 1 x USB 2.0 Connector (Type A)</li> <li>- Support 2 x M.2 Connector (PCIe Gen4 x4)</li> <li>- COM port: on board pin header</li> </ul>
<b>Storage</b>	<ul style="list-style-type: none"> <li>- Motherboard support the following SKU               <ol style="list-style-type: none"> <li>1. 4 x 2.5" HS SATA/NVMe 7mm U.2 (Support PCIe G5 x4, without UBM support)</li> <li>2. 2 x 2.5" HS SATA/NVMe 7mm U.2 (Support PCIe G5 x4, without UBM support)</li> </ol> </li> <li>- Support 2 x M.2 Connector (PCIe Gen5 x4)</li> <li>- All drives support Hot-Swap (Not include M.2)</li> <li>- Drive speed support: SATA: 6Gb/s, NVMe: PCIe G5</li> <li>- Support NVMe Surprise Removal/Add</li> </ul>
<b>PCIe Slots</b>	<ul style="list-style-type: none"> <li>- 2 x HHHL PCIe Gen5 x16*</li> <li>- Support 1 x OCP3 Gen5 x16 (CPU0)</li> </ul> All slots are PCIe Gen 2/3/4 compliant and support CXL as Intel POR.
<b>Power Supply</b>	1600W (3+1) Redundant, Platinum/Titanium
<b>Security</b>	TPM (onboard design, support by BOM option)
<b>Fan</b>	3x 8086
<b>Operating Temperature</b>	5 to 30°C **

\* PCIe Slot 1 may downgrade to Gen 4 if use 4 x UPI XCC CPU

\*\* Condition supports up to 30°C

# Chapter 2 Server System Overview

## 2.1 Chassis Dimension

850mm (D) x 442mm (W) x 87.3mm (H)

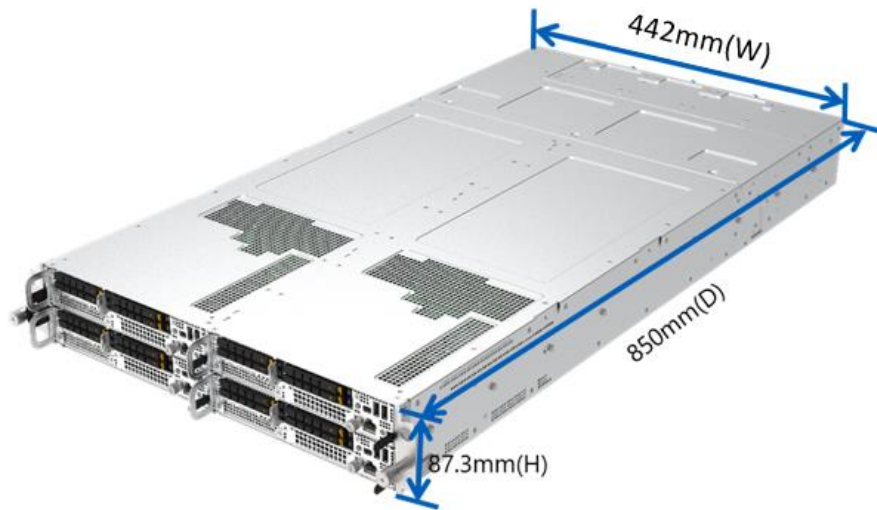

## 2.2 Front Side (In node)



Number	Component
1	Node 1
2	Node 2
3	Node 3
4	Node 4

## 2.3 System Rear View

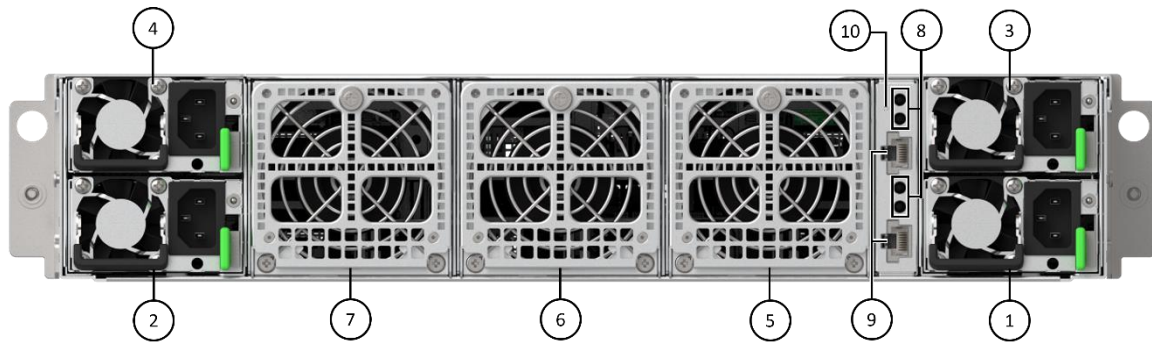

Number	Component
1	PSU 1
2	PSU 2
3	PSU 3
4	PSU 4
5	FAN 1
6	FAN 2
7	FAN 3
8	Node Health LED (top to bottom - 1, 2, 3, 4)
9	CMC Mgmt port
10	Reset Button

## 2.4 Node Support Configuration

4 SSD + 1 PCIe + OCP

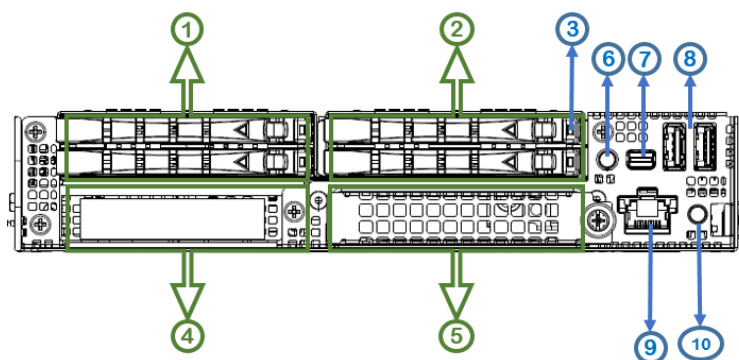

## 2 SSD + 2 PCIe + OCP

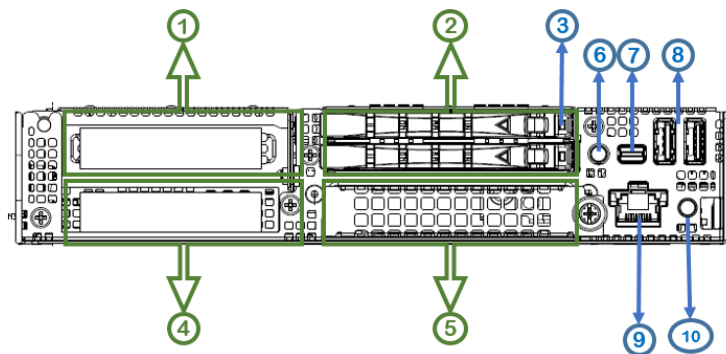

Number	Component
1	7mm SSD or PCIe Slot 2
2	7mm SSD
3	7mm SSD LED
4	PCIe Slot 1*
5	OCP 3.0
6	ID LED Button
7	Mini DP
8	USB Port Type A
9	BMC Mgmt Port
10	Power LED Button

\* There is some limitation of PCIe Slot 1, please see the detail in chapter 4.2 part “Riser Card Modules and PCIe Adapter”.

\* In 2 SSD SKU, PCIe slot 1 needs to be installed first then install slot 2.

## 2.5 Power Supply (PSU) View

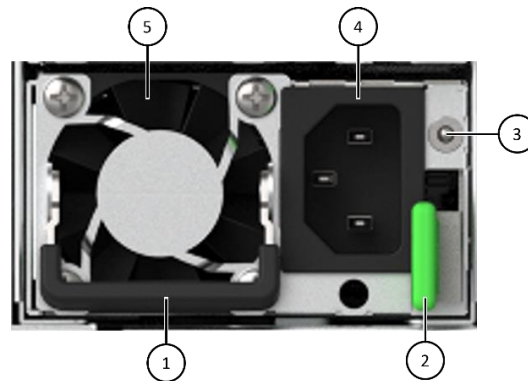

Number	Component
1	<b>PSU Handle</b> - Pull to remove the PSU
2	<b>PSU Release Latch</b> - Press to release the PSU from the system
3	<b>PSU LED Indicator</b> - Indicates the status of the power supply
4	<b>Power Connector</b> - Connects to a power source
5	<b>PSU Fan</b> – Cool fan of the PSU unit

# Chapter 3 LED Definition

## Hard Drive LEDs

The following LEDs are located on the front of node and on each individual hard drive:

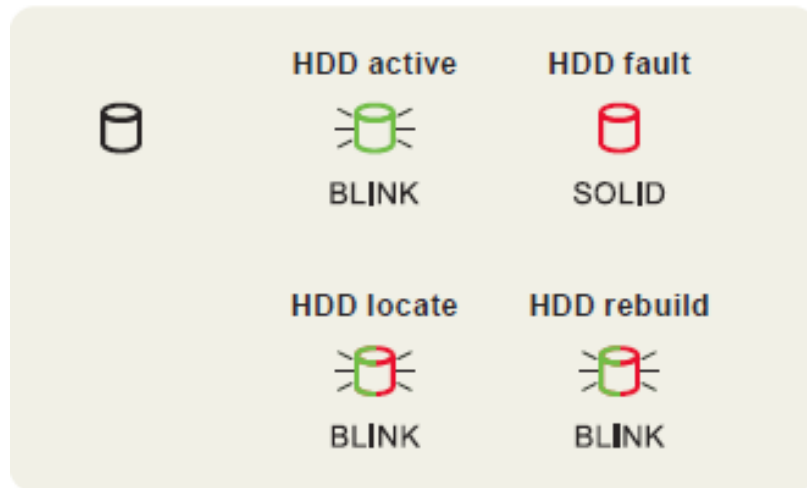

## Chassis CMC and Node BMC Management port LEDs

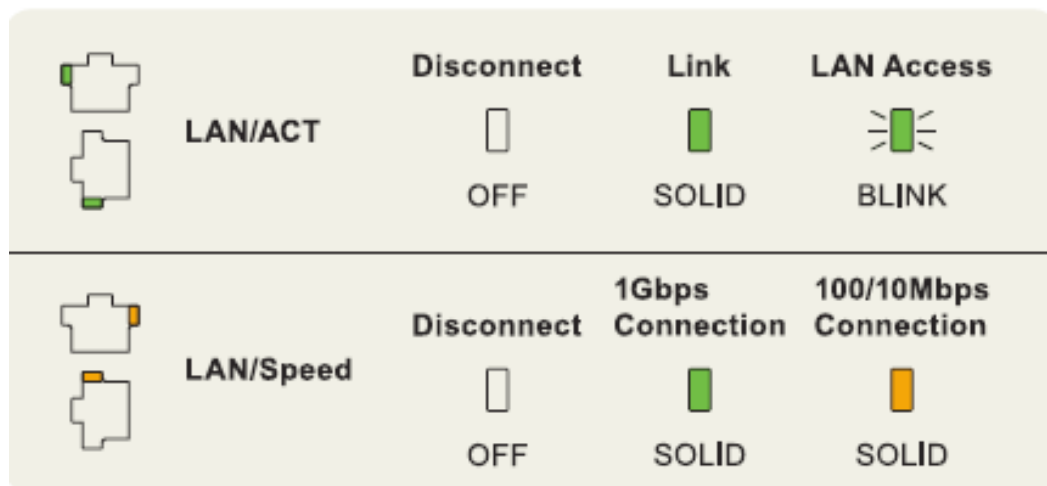

## PSU LEDs

The LED located on each PSU are bi-colored (Red & Green or Amber & Green depending on the brands of the PSU) and indicate the status of the power supply in the following mode.

### LED Definition:

Green LED	Amber LED	LED/Button Definition
On	Off	Output on and ok
Blinking (1Hz)	Off	AC present / Only +12VSB on (PS off)
Off	On	AC cord unplugged / AC power lost but a second power supply in parallel still having AC input power, or Power supply critical event causing a shutdown, such as: <ul style="list-style-type: none"> <li>• PSU OCP (Over Current Protection) failure</li> <li>• OVP failure</li> <li>• Fan failure</li> </ul>
Off	Blinking (1Hz)	Power supply warning event where power supply continues to operate, such as: <ul style="list-style-type: none"> <li>• High temperature</li> <li>• High power</li> <li>• High current</li> <li>• Slow fan</li> </ul>
Blinking (2Hz)	Off	Power supply firmware update

# Chapter 4 Installation & Removal

The following sections feature instructions on how to disassemble components that are included in the SD221-8A system. Reverse the disassembly steps to reassemble each respective component.

## 4.1 System Components

### PSU Removal

Pull the PSU handle to a 90-degree angle and press the PSU to release latch while pulling the PSU handle to remove the PSU.

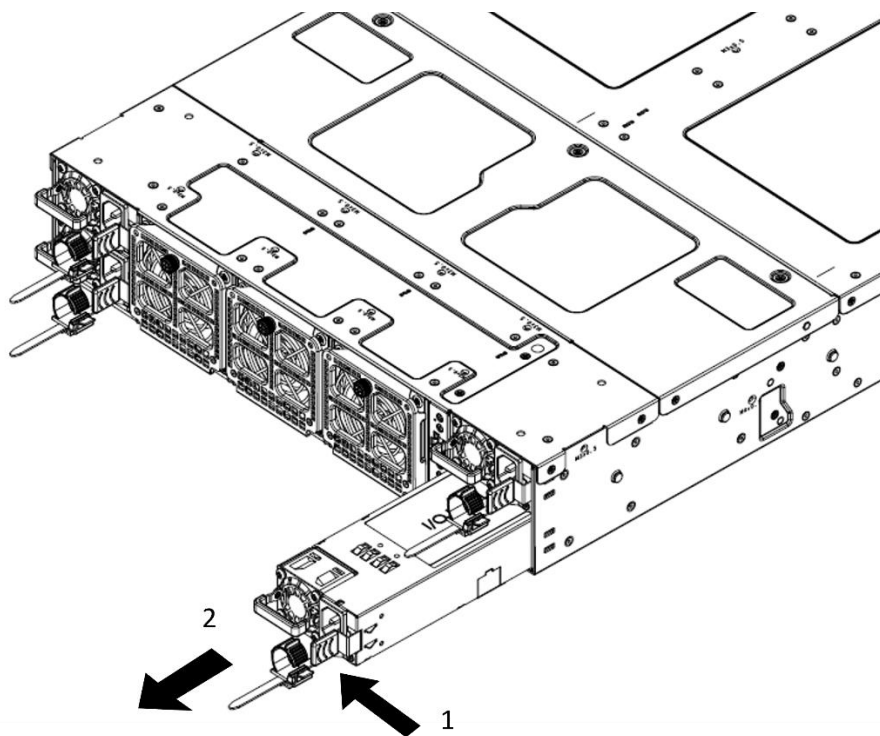

### Fan Removal

Release thumb screw and pull the handle to remove fan.

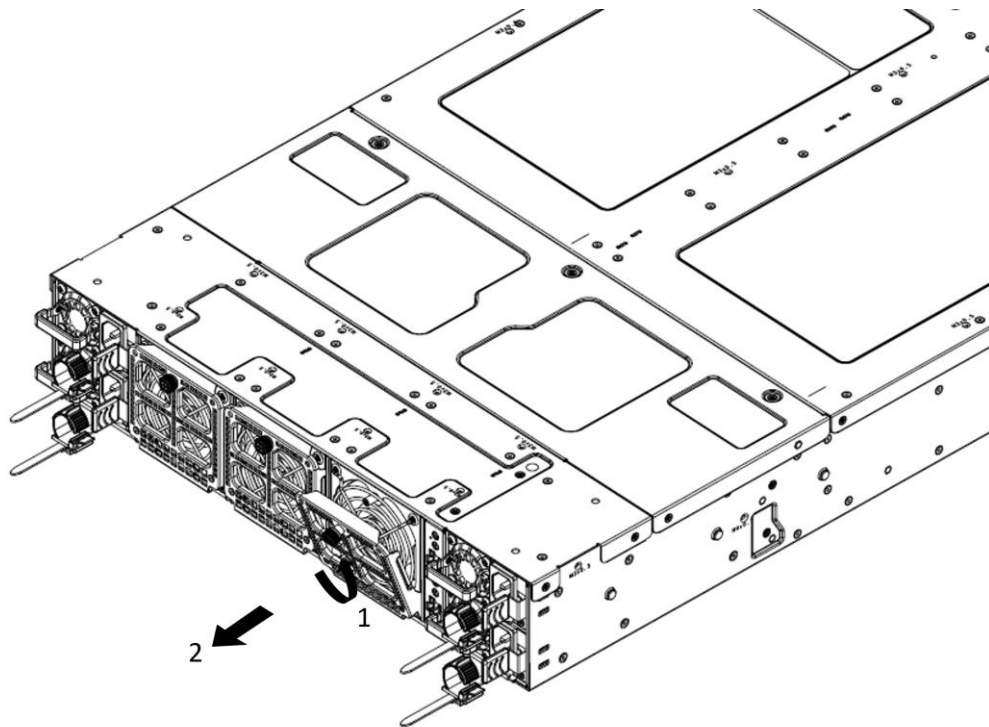

## 4.2 Node Components

### 7mm SSD Removal

1. Press the carrier release handle latch then pull the carrier release from node.

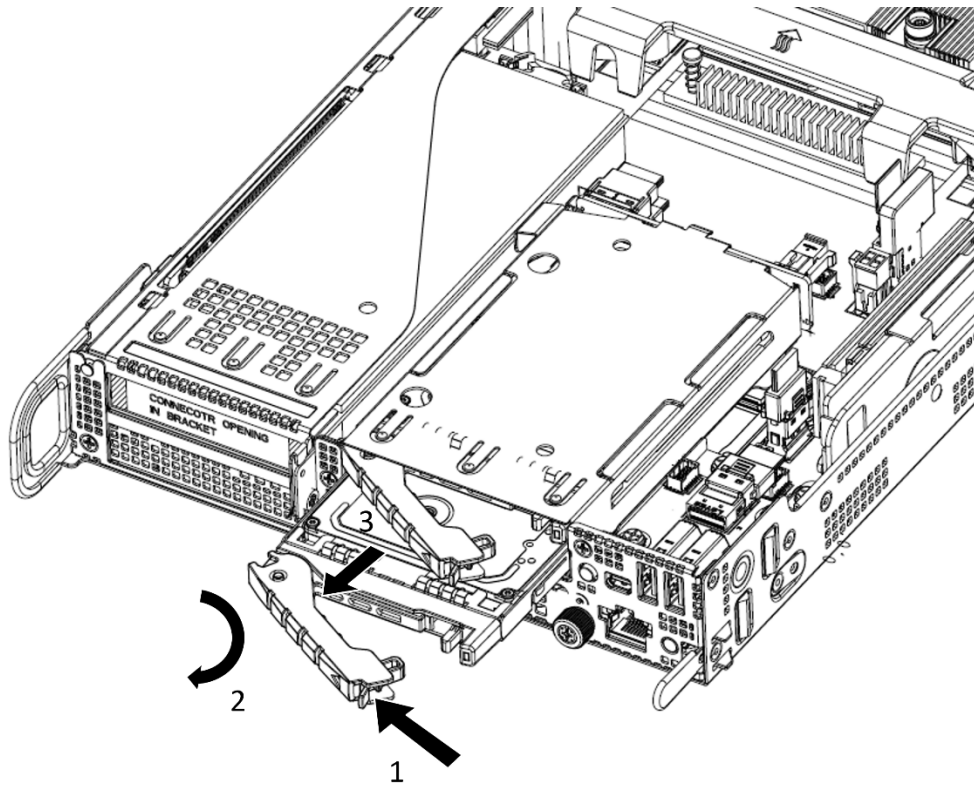

2. Remove drive from drive tray.

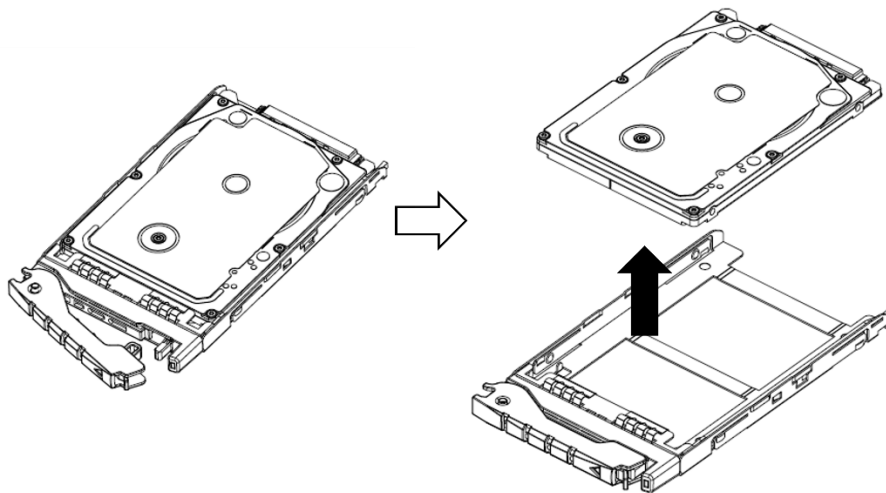

## Air Duct Removal

Loosen latches and then remove the air duct from node.

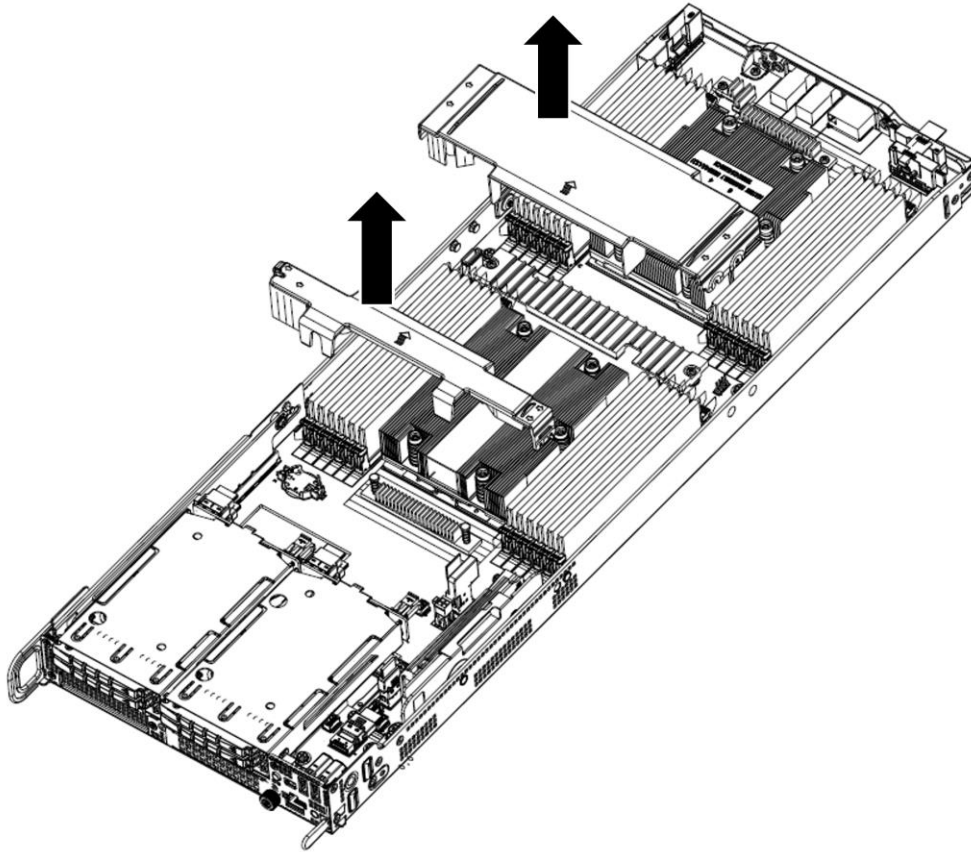

## M.2 Removal

1. Loosen the M.2 fix screw.
2. Remove M.2 module from node.

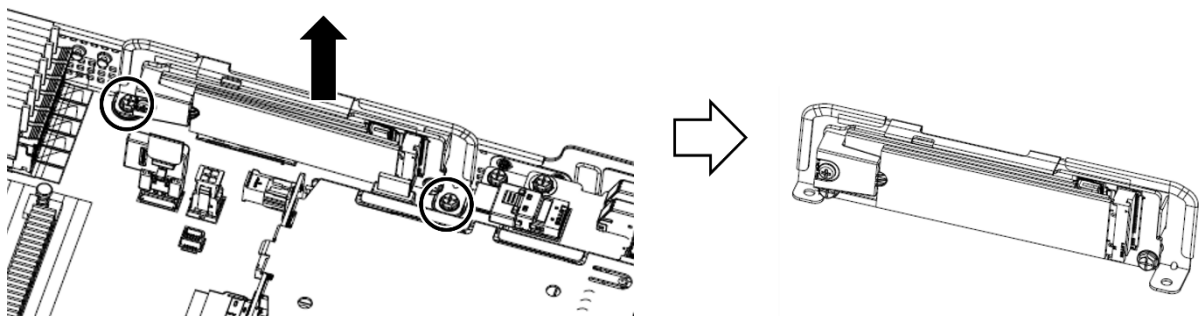

3. Remove M.2 fixture from M.2 module.

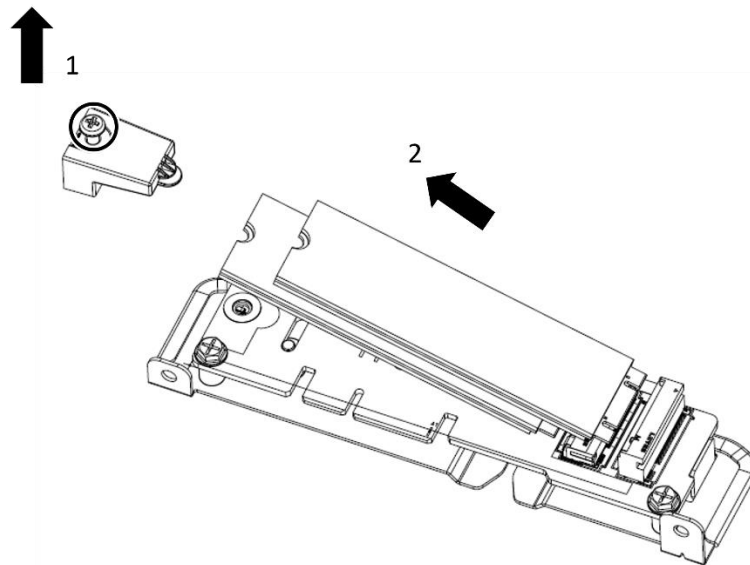

## Memory Removal

1. Push the retention clips outwards to release the memory DIMM.
2. Lift and remove the memory DIMM.

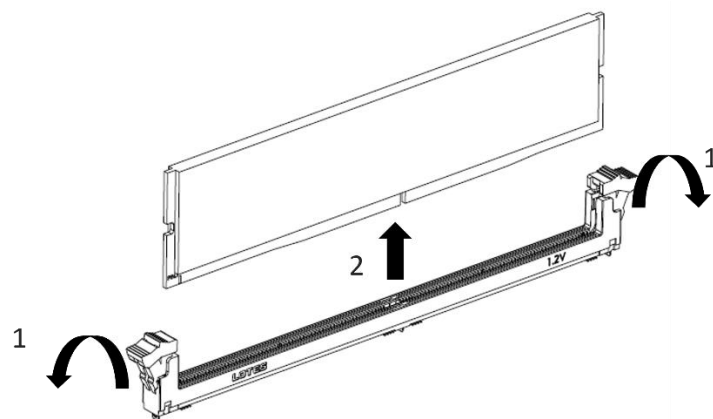

**IMPORTANT:** The server requires at least one DIMM per processor for functioning. When you install/reinstall memory DIMMs, the DIMMs sequence shown in section “DIMM Population rule” of this document to maintain performance.

## CPU & Heatsink

### 1. CPU Installation and Remove.

#### Step 1 : Open the captive screw and Retention Frame

- (1) Use T-20 6-Lobe to loosen the captive screw and away from the Retention Frame. (Fig.11)
- (2) Loosen the captive screw the Retention Frame will automatically pump up. (Fig.12)

#### Step 2 : Bounce the Rail Frame

- (1) Use your the index finger the both hands placed on Rail Frame both sides of the metal handle. (Fig.13)
- (2) Then rotate Rail frame to fully open position. (Fig.14)



Figure 11



Figure 12



Figure 13

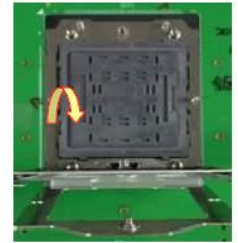

Figure 14

#### Step 3 : Insert The Package

- (1) Hold the Rail Frame, then remove the External Cap. (Fig.15)
- (2) Insert the Carrier Frame with package to the Rail Frame slot by holding the finger grip. (Fig.16&17)

#### Note:

1. Don't touch the package pad.(Fig.C)
2. Carrier Frame should slide into Rail Frame slot when insert the Package.
3. Warning! Be sure Carrier Frame with Package may be drop off if Frame did not fix by Rail Frame slot. Make sure carrier frame will slightly "click" with rail frame. Carrier Frame drop off will damage socket cap & contact.



Figure 15

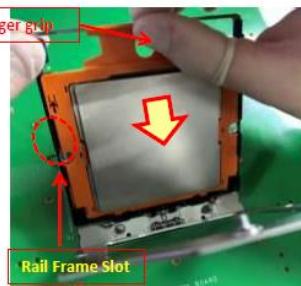

Figure 16

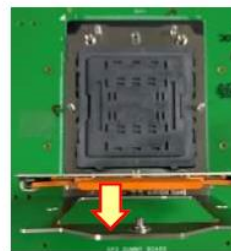
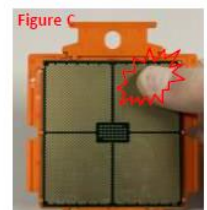

Figure 17



### Step 4 : Removal PnP Cap

- (1) Use thumb and forefinger to hold the removal tap of PnP Cap. (Fig.18-1)
- (2) Carefully remove the PnP Cap in a vertical motion only. (Fig.18-2)

**Note: Don't let PnP Cap touch contact when removing PnP Cap.**

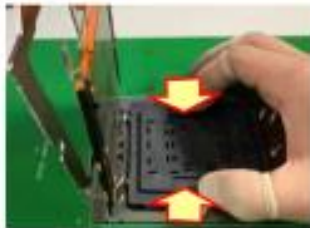

Figure 18-1



Figure 18-2



Figure 19

### Step 5 : Assemble Package and SRM

- (1) Use the finger of two hands to press the Rail Frame with package on Stiffener Frame. Slightly press down with "click" feeling. (Fig.20)
- (2) Press Retention Frame and then tighten the captive screw. (Fig.21)
- (3) Final status of whole assembly process as Fig.22

**Note:**

1. Be care that Carrier Frame drop-off with abnormal operation, Socket contact will be damaged.
2. Torque : 12.5-15kgf-cm



Figure 20

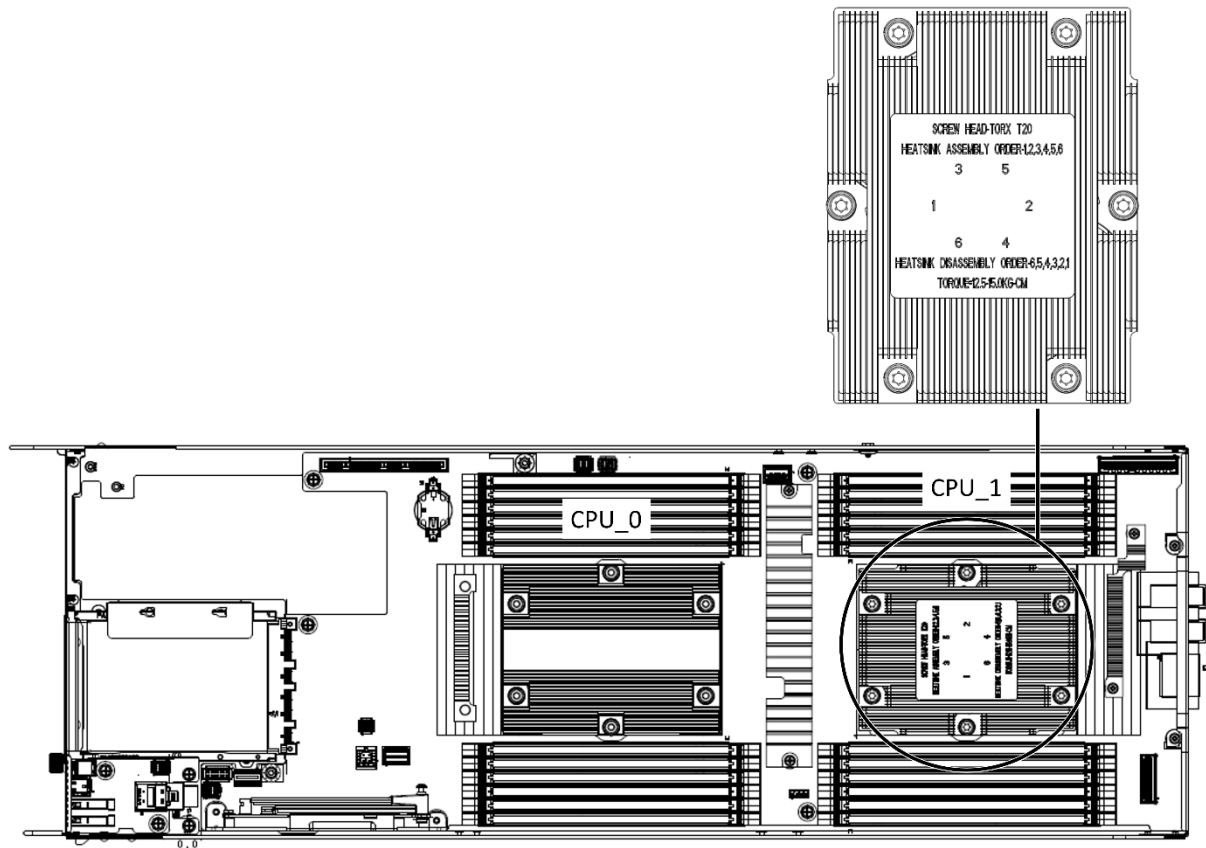

Figure 21



Figure 22

2. Follow instruction to fasten screws.



**IMPORTANT:** When reinstalling CPU heatsink 0, ensure that it is installed on CPU Slot 0 of the node. Incorrect placement and orientation of the heatsink will result in improper airflow within the system which may overheat the system.

**IMPORTANT:** When reinstalling the CPU heatsink, tighten the 4 captive screws in sequential order based on the diagonal. Incorrect sequence will result in an uneven application of the thermal grease on the CPU.

## Riser Card Modules and PCIe Adapter

### - 2 SSD SKU

1. Screw removal and remove Riser Card Module.

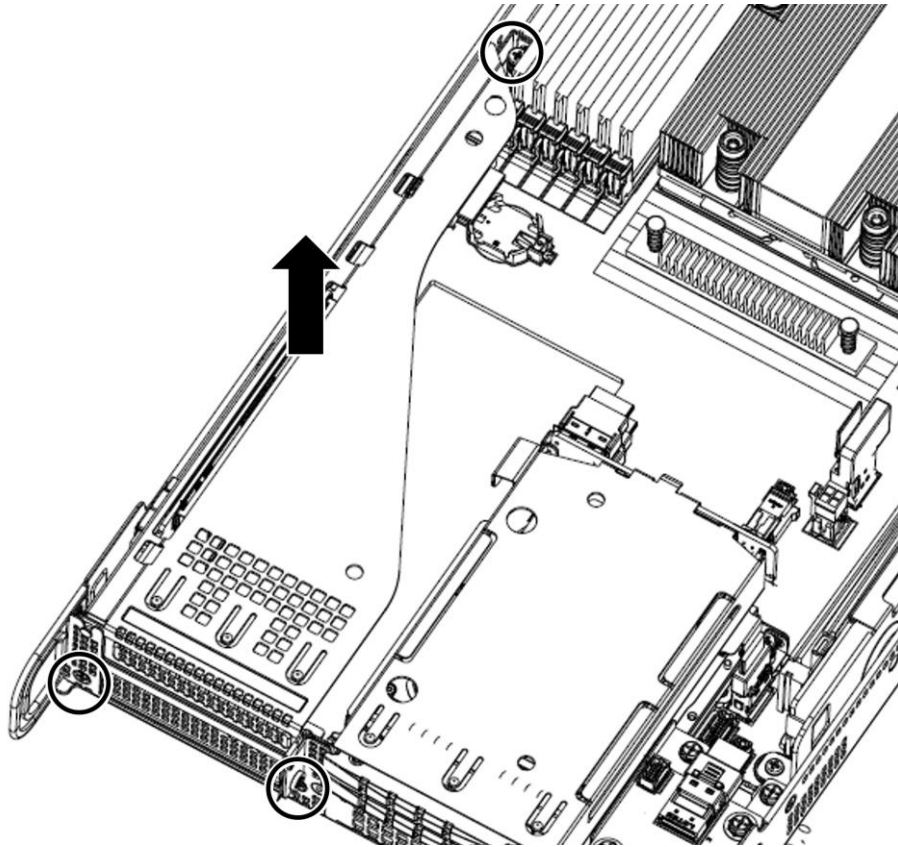

2. Remove dummy

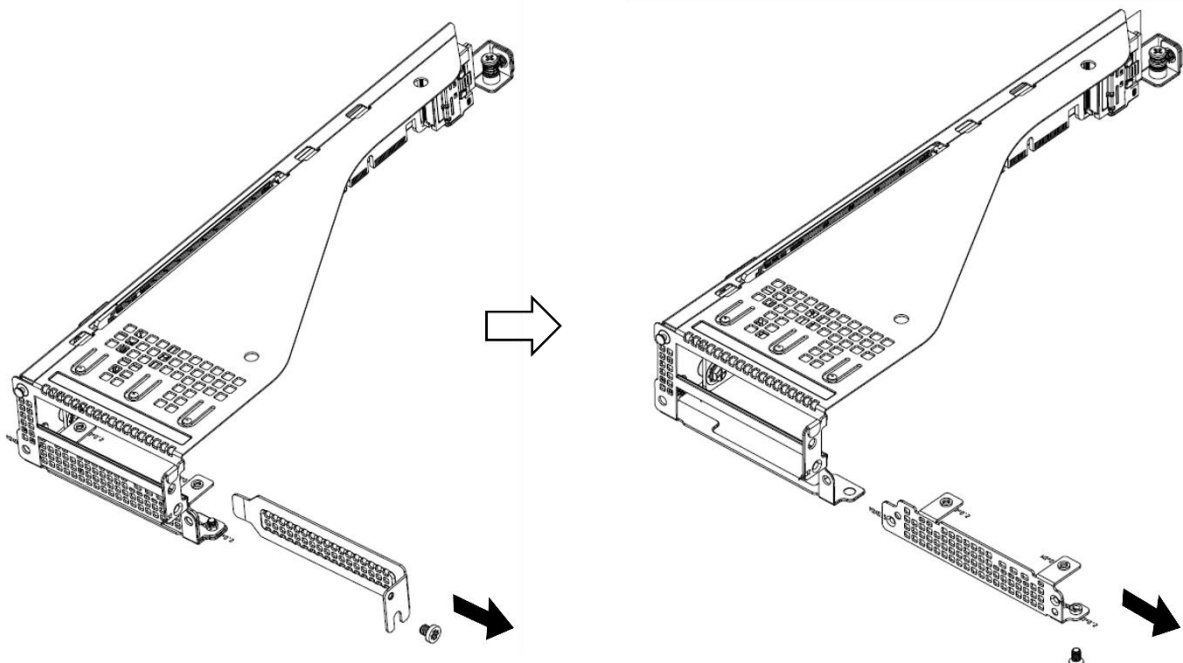

4. Install PCIe adapter card and tight the screw.

PS1. This slot of adapter needs to replace card's bracket and insert back to riser.  
COMPALSERVER

PS2. This slot's bracket does not support for external device due to bracket was closed type as figure below.

PS3. This slot only supports standard low profile half-length PCIe adapters limited by space.

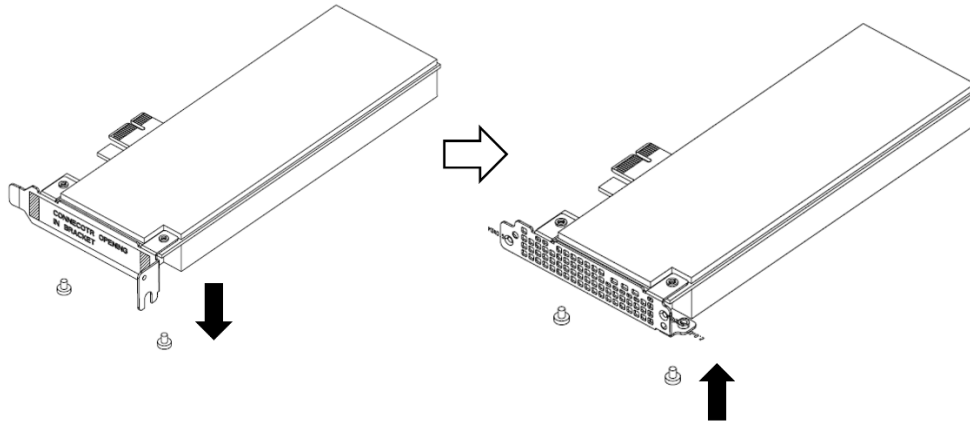

#### 4. Install PCIe adapter to Riser Module

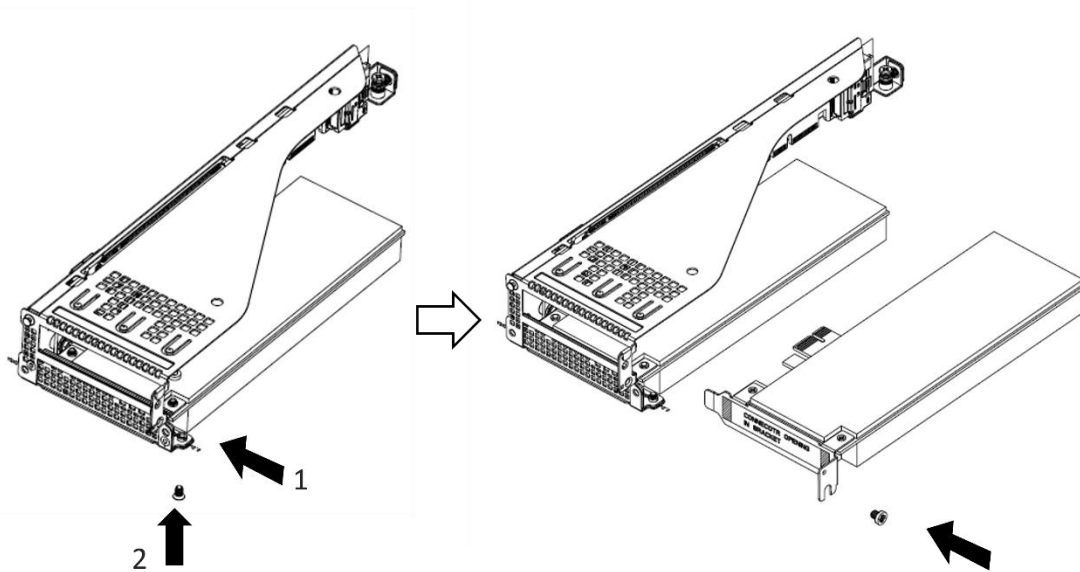

PS1. In this SKU, PCIe slot 1 need be installed first then install slot 2.

- 4 SSD SKU

COMPALSERVER

1. Remove SSD from node first.

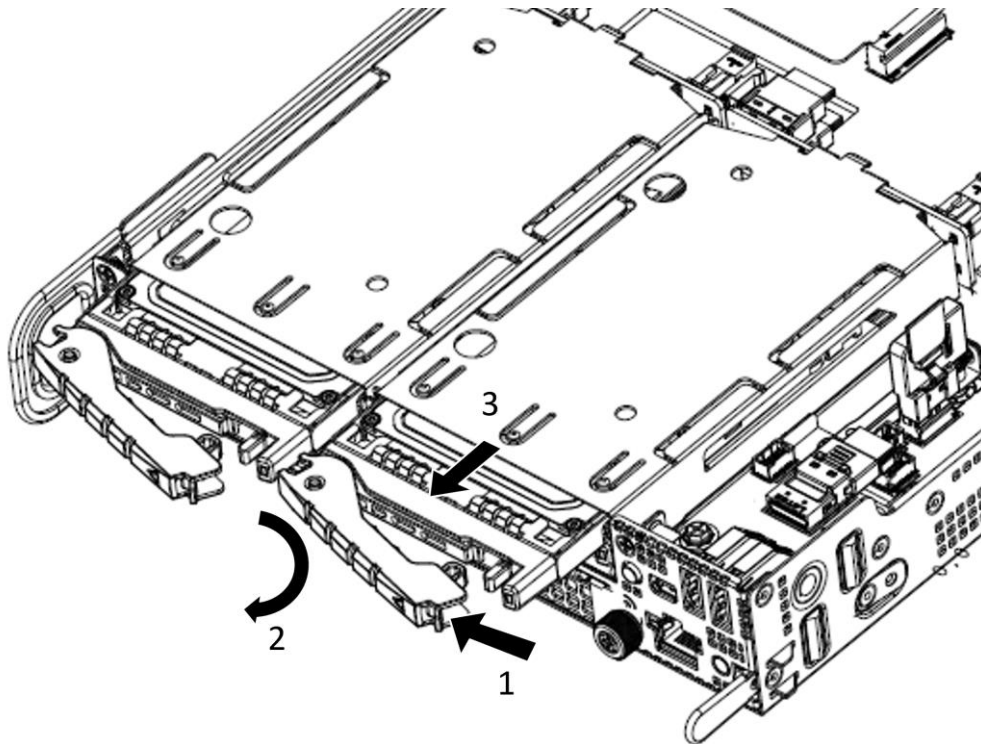

2. Release SSD cage fixed screw and remove SSD cage from node tray.

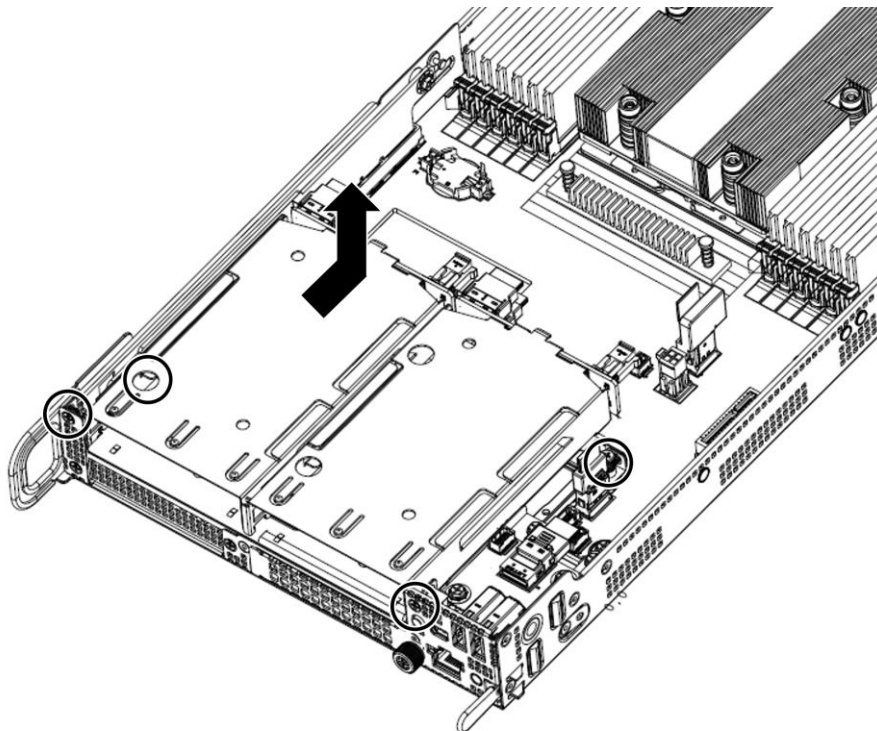

3. Release Riser fixed screw and then remove Riser module

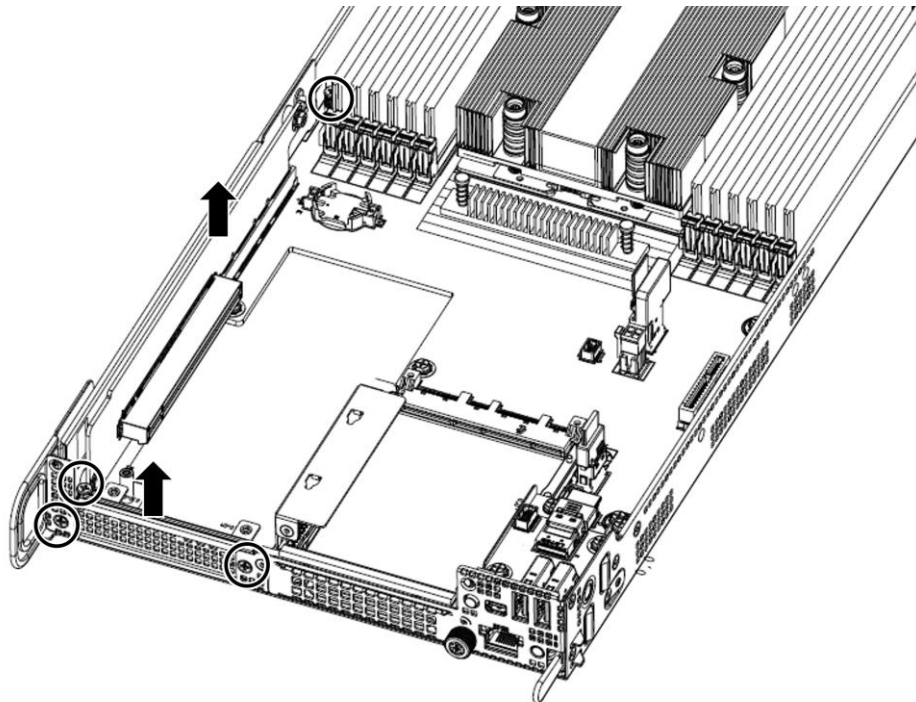

4. Install PCIe card into Riser then it can be installed back to node.

PS1. This slot of PCIe needs to replace card's bracket and insert back to riser.

PS2. This slot's bracket does not support for external device due to bracket was closed type as figure below.

PS3. This slot only supports standard low profile half-length PCIE adapters limited by space.

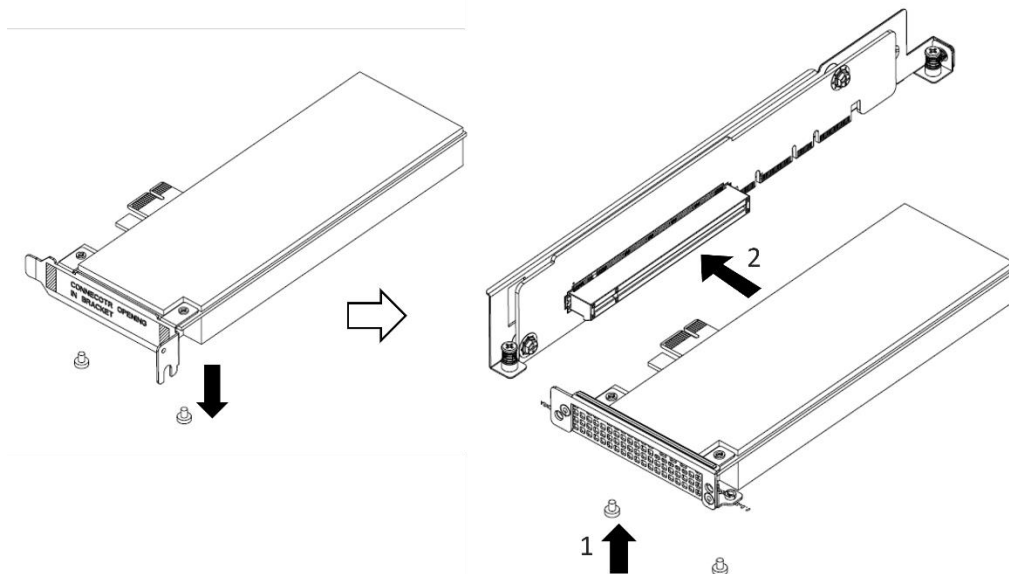

## 4.3 Chassis Rail Kits

1 Remove the inner rail

Note: Please check rack post type. The rail pre-installed type is for square hole post. If rack post is round hole post or screw hole post, please switch to the suitable pins.

A Square Hole Pin (For □9.5)  
B Round Hole Pin (For ∅7.1)  
C Screw Hole Pin (For #10-32 or M5)

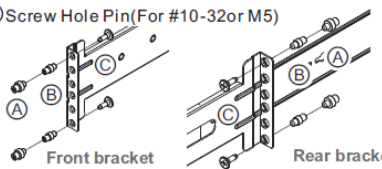

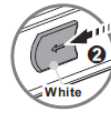

Pull tab forward and take out inner rail.

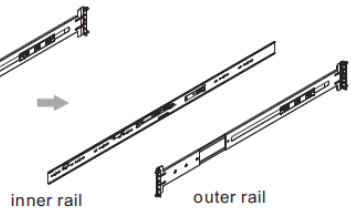

inner rail      outer rail

2 Install the inner rail onto the chassis

**1 Key Hole.**

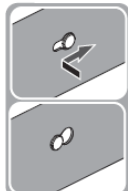

**2 Screw Hole.**

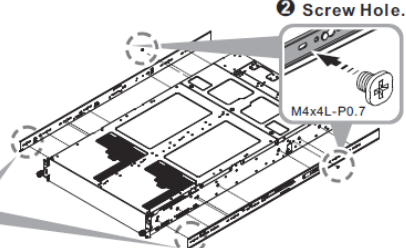

**1**

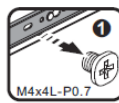

M4x4L-P0.7

**2**



Lift the latch to remove standoff from the keyhole

3 Fix the outer rail/bracket assembly to the frame

**Rear bracket**  
\*fasten screw into third bracket hole from the top

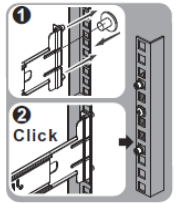

**1**

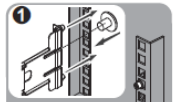

**2** Click

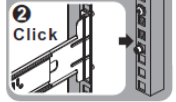

**Front bracket**  
\*fasten screw into second bracket hole from the top

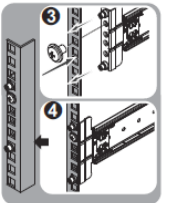

**3**

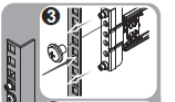

**4**

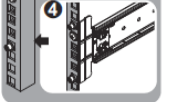

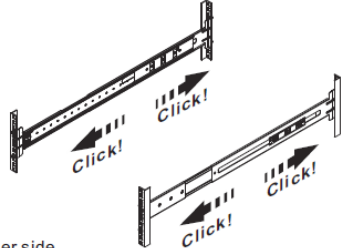

Click!      Click!

Click!      Click!

**Front bracket**      **Rear bracket**

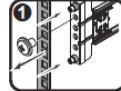
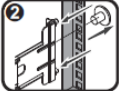
**1**      **2**

Please repeat the detachment steps for the other side.

4 Insert the chassis to complete the installation

**1** Fully extend rail to lock position, and make sure the ball bearing retainer is located at the front of the rail.

**2** Insert the chassis into outer rails.

**3** When hit a stop, please pull / push the release tab on the inner rails.

**4** Tighten chassis with shipping screws.

**1 2** Unfasten shipping screws to pull out chassis.

**3 4** Pull the disconnect tab forward to remove chassis at its fully extended position.

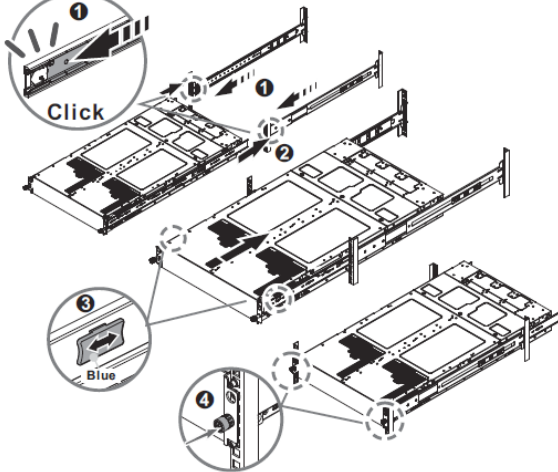

**1** Click

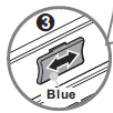

Blue

**4**



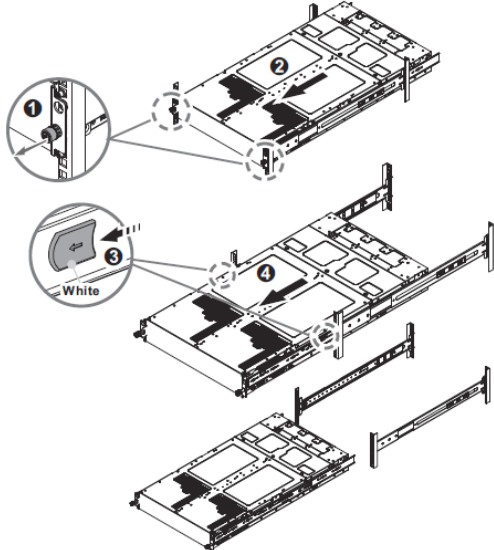

**1**

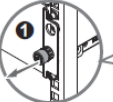

**2**

**3**



White

**4**

# Chapter 5 Motherboard Overview

## 5.1 Connectors

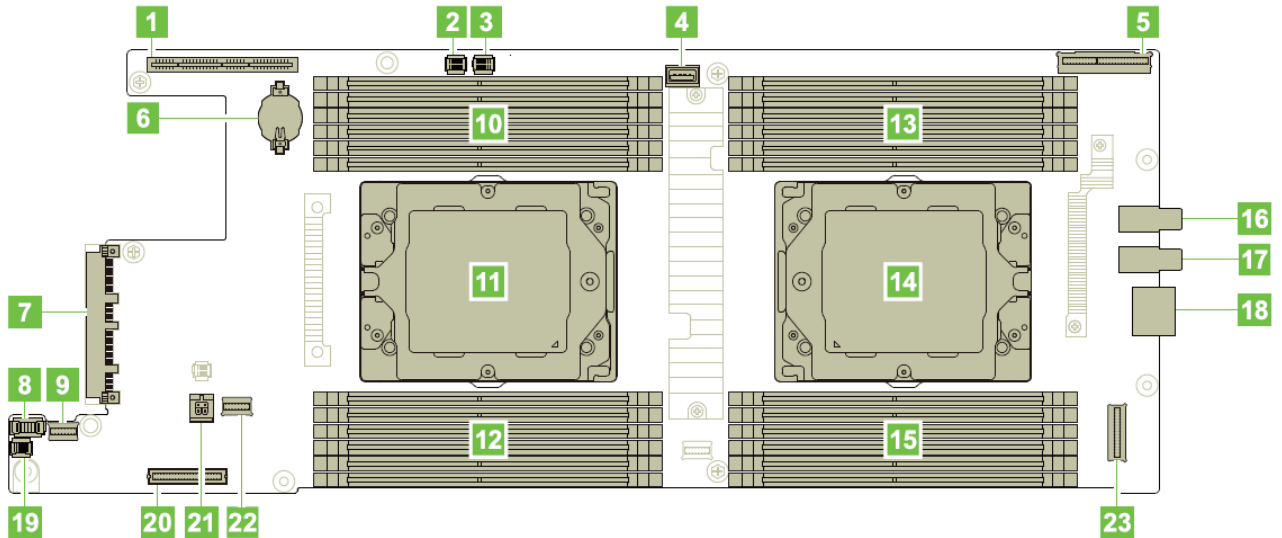

Item	Function	Item	Function
1	GenZ Slot CONN.4C+ X16 (CPU_0)	13	DDR DIMM (CPU_1)
2	HDD BP Control CONN.	14	CPU_1
3	HDD BP Control CONN.	15	DDR DIMM (CPU_1)
4	Internal USB 2.0 (Type A)	16	System Power CONN.
5	PCIe x16 Riser (CPU_1) / NVMe SSD (Slot 0~3)	17	System Power CONN.
6	RTC Battery	18	Mid-Plane Signal CONN.
7	OCP 3.0 x16 (CPU_0)	19	Top IO Power CONN.
8	Bottom IO CONN.	20	GenZ 2C M.2 Riser (CPU_0)
9	Top IO CONN.	21	HDD BP Power CONN.
10	DDR DIMM (CPU_0)	22	SATA Signal CONN.
11	CPU_0	23	NVMe SSD (Slot 0~1)
12	DDR DIMM (CPU_0)		

## 5.2 CPU Sockets and DIMM Slots

SD221-8A support 12 channels in each processor, and 1DPC (one DIMM per Channel), DIMM order listed as below.

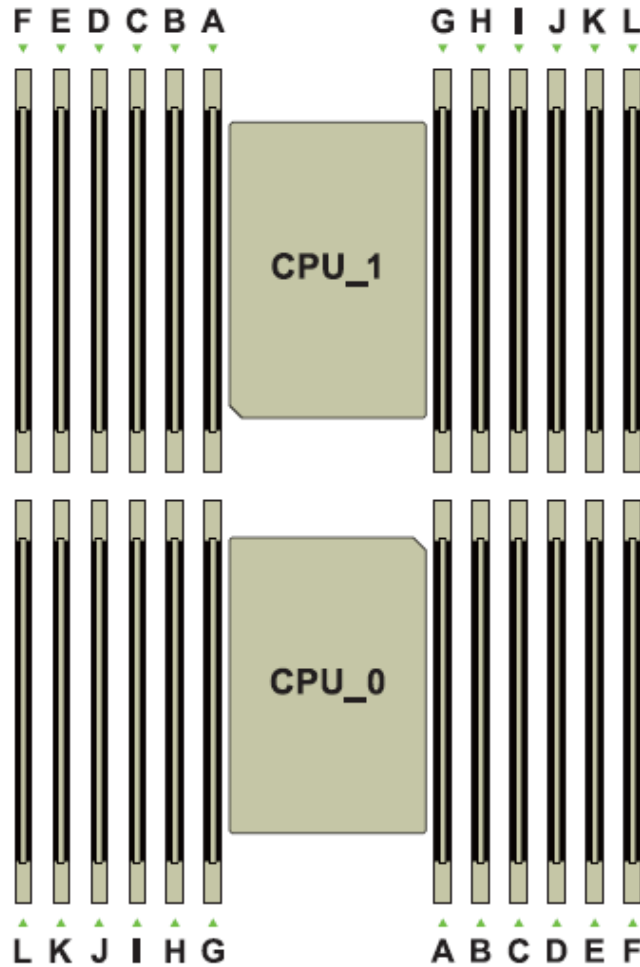

### DIMM Population rule

	CH_L	CH_K	CH_J	CH_I	CH_H	CH_G		CH_A	CH_B	CH_C	CH_D	CH_E	CH_F	
1 DIMM							CPU	DDR5						
2 DIMM						DDR5		DDR5						
4 DIMM				DDR5		DDR5		DDR5		DDR5				
6 DIMM				DDR5	DDR5	DDR5		DDR5	DDR5	DDR5	DDR5			
8 DIMM		DDR5		DDR5	DDR5	DDR5		DDR5	DDR5	DDR5	DDR5		DDR5	
10 DIMM		DDR5	DDR5	DDR5	DDR5	DDR5		DDR5	DDR5	DDR5	DDR5	DDR5	DDR5	
12 DIMM	DDR5	DDR5	DDR5	DDR5	DDR5	DDR5	DDR5	DDR5	DDR5	DDR5	DDR5	DDR5	DDR5	

# Chapter 6 System Management

## 6.1 Management topology

SD221-8A CMC support to manage chassis and each node. Please based on necessary to connect network cable. System node support 3 ports for BMC IP to access from outside.

1. BMC Dedicate NIC (connect from Node directly)
2. BMC Dedicate NIC (Over CMC port)
3. BMC Share NIC (NCSI)

First initial system, please get CMC IP via any node’s BMC. Example by ipmitool below.

```
$ ipmitool -H <<Node's BMC IP>> -U admin -P admin -I lanplus raw 0x3e 0x7f 0x01 0xd6
```

Tool responds example as “01 d6 04 C0 A8 01 02”, the last 4 bytes (C0 A8 01 02) were CMC’s IP in HEX, in this example, it was 192.168.1.2.

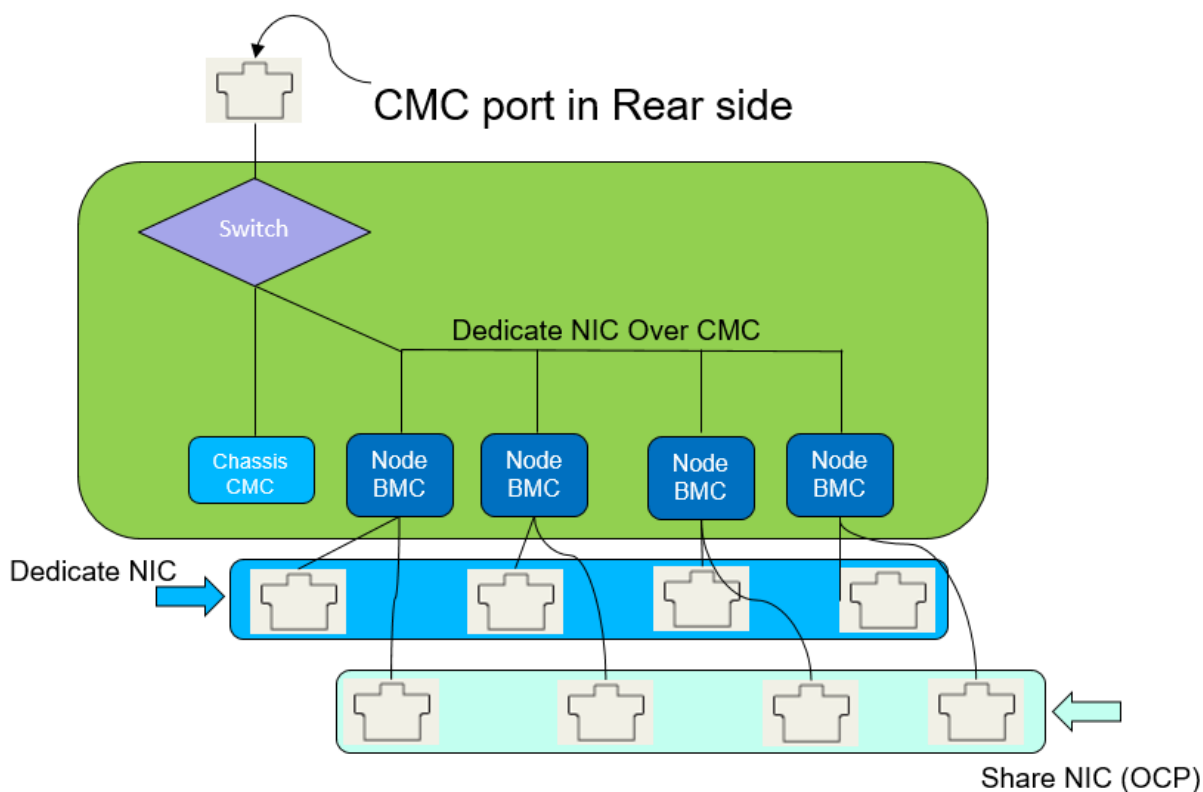

1. Connect CMC Port to get CMC IP and all node’s BMC IP (Dedicate over CMC)
2. Connect Node’s Dedicate NIC to get Node’s Dedicate BMC IP.
3. Connect Node’s Share NIC to get Node’s Shared BMC IP.

## 6.2 Chaining Management

SD221-8A CMC support to manage chassis and each node via 1 switch port, called Chaining Management. Connect the CMC ports using Ethernet cables in a daisy chain fashion.

Connect the first CMC port to your network switch or router, and then connect the second CMC port to the next server's first CMC port, and so on.

By connecting the CMCs in a daisy chain, you streamline the management of the entire server setup. Additionally, ensure that your network configuration supports the communication between the CMCs and other management tools.

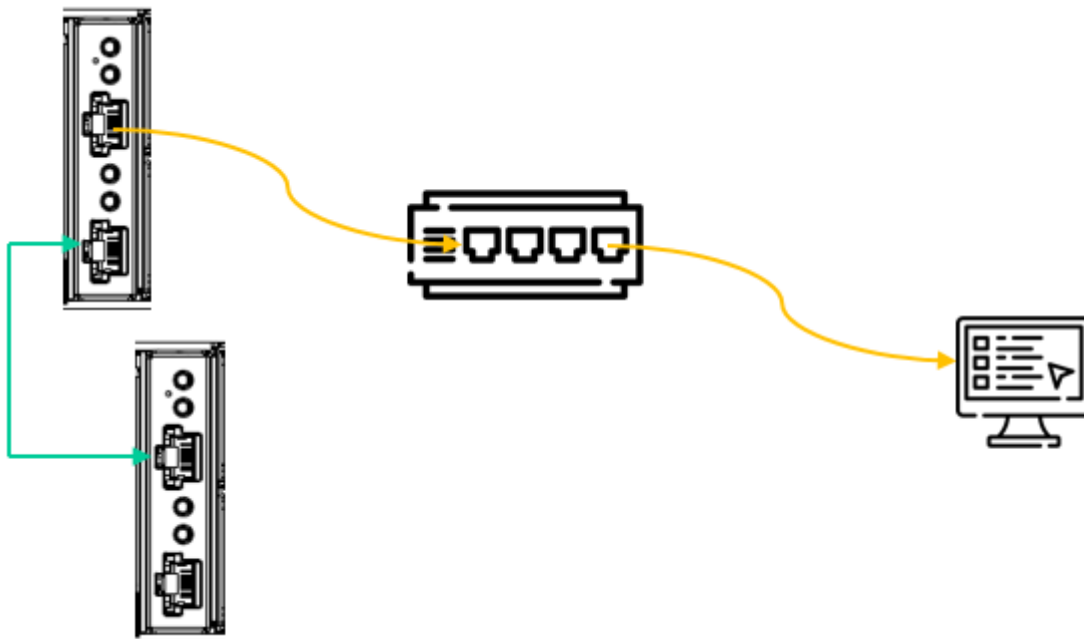

# Chapter 7 System Operation Mode

## 7.1 Performance Mode settings

System was “Balance” for better power efficiency in system default settings. It can be modified to “Performance Mode” for best performance.

※ AMD XGMI speed will change by this setting, please set to “Performance Mode” for best performance.

1. Press “F1” in POST stage to enter uEFI setup menu.

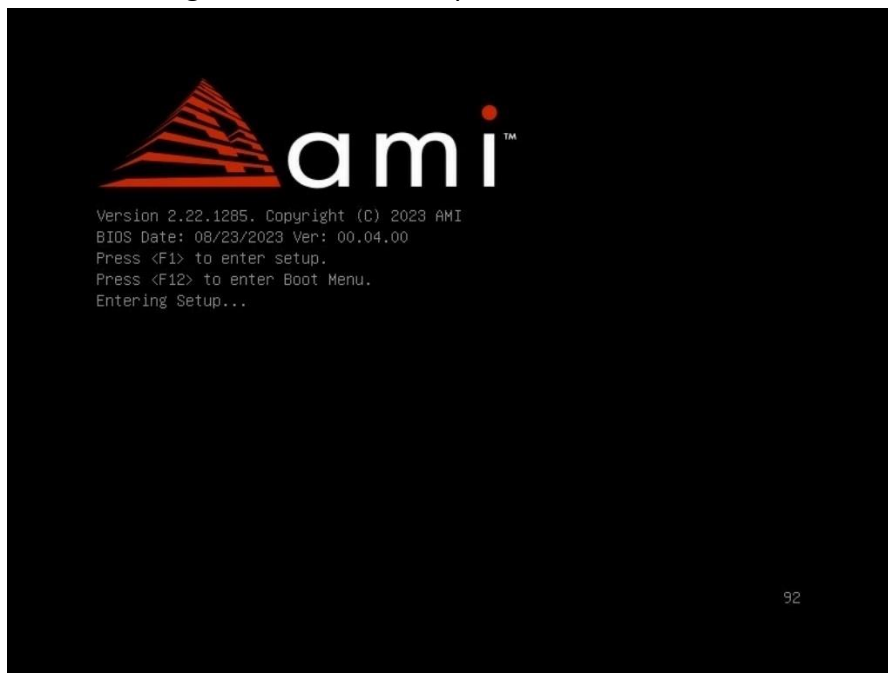

2. Navigate to “Advanced” => “Performance Mode” and change “Performance Mode” to “Performance”

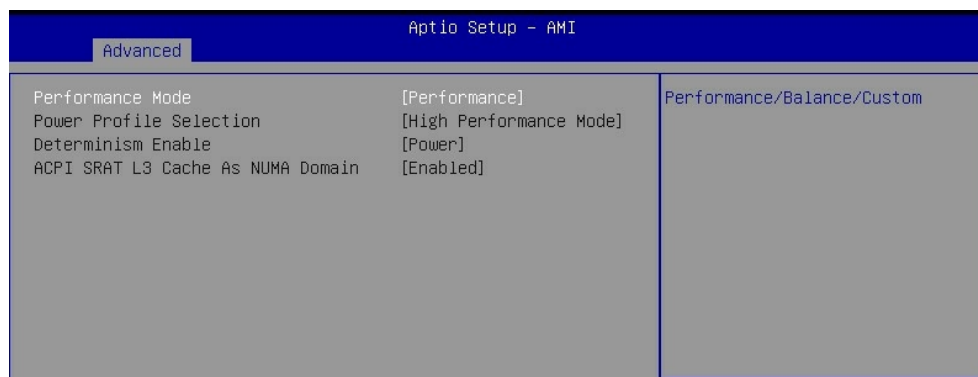

3. Press “F4” to “save & Exit”

==Document END==